

BS Series



※Scan with your
smart phone online!

Brushless DC Motor Driver User's Manual

 Made by TROY Enterprise Co., Ltd

Environment Responsibility

- TROY is always committed to environment protection. All packaging material is recyclable and reusable.
- If disposing of used product, please recycle by type as per waste disposal procedures.

-----Protect the green earth with your care and commitment-----

※The product is subject to design modification for performance improvement without prior notice.
For more details please contact your local seller.

Contents

1.	Precautions	3
1.1	Features.....	3
1.2	Checking the package content.....	3
1.3	Precaution for operation.....	3
2.	Systems configuration	4
2.1	Single phase power AC110V or AC220V wiring diagram.....	4
3.	Specs	5
3.1	Specs (20W~75W)(1/38hp~1/10hp).....	5
3.2	Specs (120W、200W)(1/6hp、1/4hp)	6
3.3	Product number code of driver.....	7
3.4	Product number code of Motor.....	7
4.	Names and functions of driver	8
4.1	Driver panel.....	8
4.2	Functions of driver (20W~120W)(1/38hp~1/6hp)	9
4.3	Functions of driver (200W)(1/4hp)	11
5.	Installation	13
5.1	Installation conditions.....	13
5.2	Regenerative resistor & Speed potentiometer VR dimension (Attachment)	13
5.3	Driver dimension for 20W/40W/75W/120W(1/38hp,1/19hp,1/10hp,1/6hp)	14
5.4	Driver dimension for 200W(1/4hp)	14
5.5	Driver installation.....	15
5.6	Regenerative resistor installation.....	16
5.7	Driver connection.....	17
5.8	Precaution and specs for Motor extension cable.....	17

6.	Connection	18
6.1	Precaution of signal input & output terminal connection.....	18
6.2	Precaution for power supply connection.....	18
6.3	Wiring diagram.....	19
6.4	Signal input and output.....	20
7.	Operation	22
7.1	Operation mode setting.....	22
7.2	Protection functions.....	24
7.3	ALARM release.....	25
7.4	Noise prevention.....	25
7.5	The meaning of ALARM protection functions.....	25
7.6	Parallel operation/Multi-speed control/Voltage control.....	26
7.7	DC voltage-speed characteristics (2500r/min)	28
7.8	Speed potentiometer dial scale-speed characteristics (2500r/min)	28
7.9	DC voltage-speed characteristics (3000r/min)	29
7.10	Speed potentiometer dial scale-speed characteristics (3000r/min)	29
8.	Before using	30

1. Precautions

1.1 Features

- Easy position control
- Surge protection
- Attached the external regenerative resistor and customer can select it according the load (200W)
- Built-in protect functions such as over voltage, over load, instantaneous over current, over heat and out of phase

1.2 Checking the package content

Upon opening the package, verify that the items listed below are included. Report any missing or damaged items to the local seller which you purchased the product.

- BS driver.....1pc
- User's manual.....1pc
- 12 Pins terminal.....1pc
- 2 Pins terminal (Vertical entry).....1pc
- Variable resistor 20K.....1pc
- RG 2 Pins terminal (Horizontal entry) for 200W(1/4hp) included 20W/40W/75W/120W (1/38hp,1/19hp,1/10hp,1/6hp) sold separately.....1pc
- 120W(1/6hp)/470Ω regenerative resistor 200W(1/4hp) included (20W/40W/75W/120W)(1/38hp/1/19hp/1/10hp/1/6hp) sold separately.....1pc
- Noise filter.....1pc
- Accessories

Mounting bracket X 2pcs/M3 with 4mm/Flat screws X 4pcs/Signal cable for connecting the external potentiometer X 1pc

1.3 Precaution for operation

Before use:

- Do not use the product in explosive or corrosive environments.
- Driver must be connected with FG ground terminal.
- When installing the Motor into your equipment, ensure that Motor cable、Power cable、I/O、ground lead are fixed and do not move. In addition, do not apply any pressure to these cables.
- Before installation please check the terminal is connect to the proper place without loosing
- Installation must be performed by a qualified installer.

When use:

- Please turn off the driver power before using or inspection.
- If a Motor is accessible during operation; post a warning label shown in the figure in a conspicuous position to prevent the injury.
- Do not touch the connection terminals of the driver when it electricity. It may cause the electric shock or fires.

2. System configuration

2.1 Single phase power AC110V or AC220V diagram

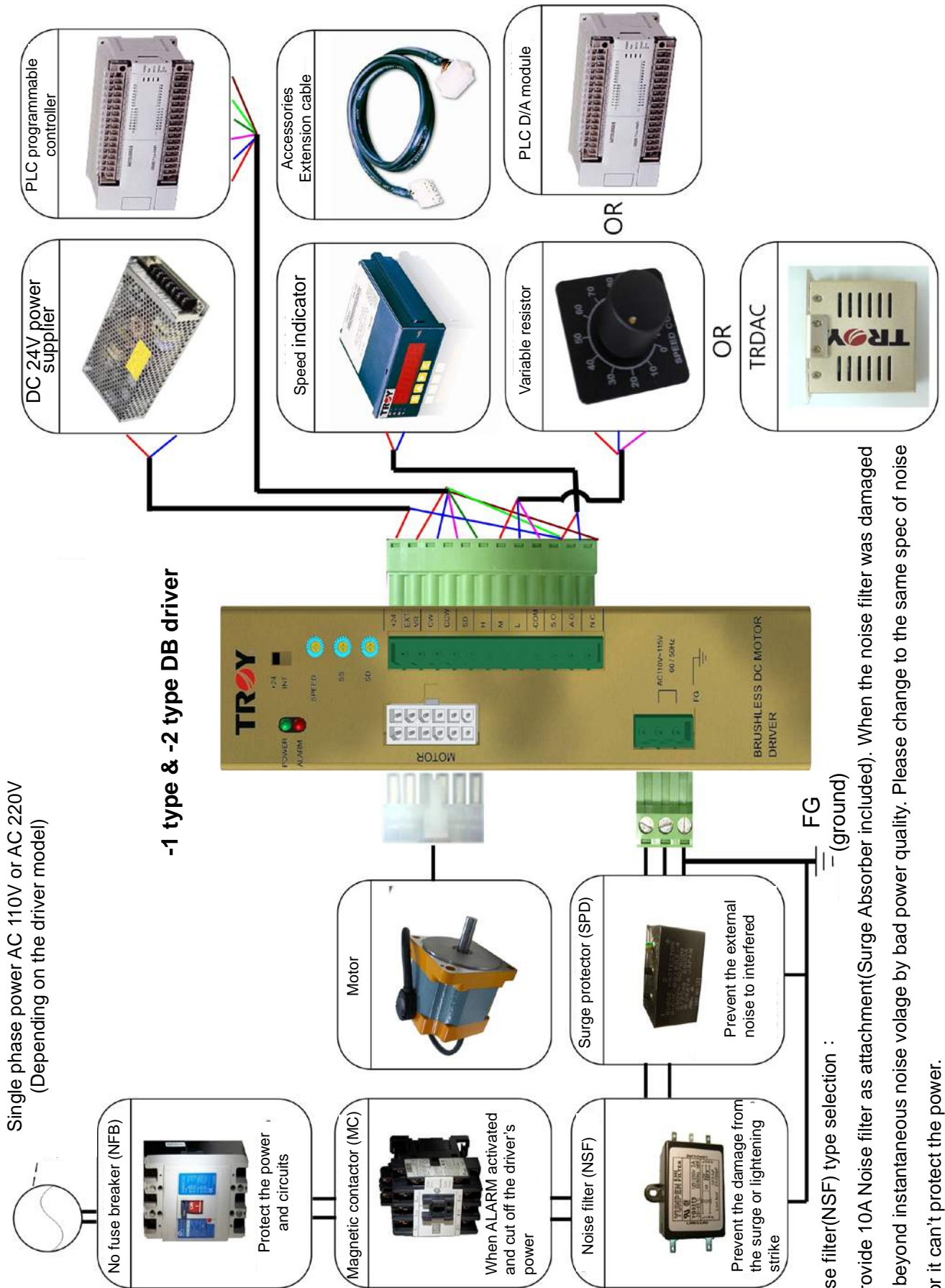

Single phase power AC 110V or AC 220V
(Depending on the driver model)

-1 type & -2 type DB driver

- Noise filter(NSF) type selection :
We provide 10A Noise filter as attachment(Surge Absorber included). When the noise filter was damaged since beyond instantaneous noise voltage by bad power quality. Please change to the same spec of noise filter or it can't protect the power.
- Surge protector(SPD) wiring attention :
Wiring is different due to different brands, please refer to each brand's wiring diagram.

3.Specs

3.1 Specs(20W~75W)(1/38hp~1/10hp)

Motor output		20W(1/38hp)	40W(1/19hp)	75W(1/10hp)	
Round shaft	AC110~115V	6B020S-1	6B040S-1	9B075S-1	
	AC220~230V	6B020S-2	6B040S-2	9B075S-2	
Pinion shaft	AC110~115V	6B020P-1	6B040P-1	9B075PD-1	
	AC220~230V	6B020P-2	6B040P-2	9B075PD-2	
Driver model	AC110~115V	DB020-1	DB040-1	DB075-1	
	AC220~230V	DB020-2	DB040-2	DB075-2	
Power input	-1 type (single phase) AC110~115V,50/60Hz	Max current	2.8A	2.8A	2.8A
		Rated current	0.65A	1.2A	1.95A
	-2 type (single phase) AC220~230V,50/60Hz	Max current	1.6A	1.6A	1.6A
		Rated current	0.35A	0.65A	1.05A
Starting torque(kgcm/Nm)		0.8/0.08	1.6/0.16	3.3/0.33	
Rated torque(kgcm/Nm)		0.65/0.065	1.4/0.14	2.5/0.25	
Permissible load inertia(GD ²)		4.78kgcm ²	9.55kgcm ²	17.45kgcm ²	
Min speed (r/min)		300	300	300	
Max speed(r/min)		3070	3070	3070	
Speed regulation	To load	Max.±0.05(3000 r/min, within no load~rated load)			
	To voltage	±0.05%(Power supply voltage ±15%,at 3000 r/min with no load)			
	To temperature	±0.05%(0~40℃,at 3000rpm with no load)			
Speed control		<ul style="list-style-type: none"> ●Controlled by external potentiometer(Variable resistor 20kΩ) ●Controlled by built-in potentiometer ●Controlled by DC voltage(0~5V) ●Work with D/A speed setter panel (Option) 			
Signal output/input		<ul style="list-style-type: none"> ●Photo coupler input ●Open collector output 			
Function		<ul style="list-style-type: none"> ●Zero point control ●Motor flat torque output ●Instantaneous brake ●SLOW START/SLOW DOWN ●Parallel operation 			
Protection function		<p>When the following are activated the alarm signal will be output and the Motor will come to a natural stop(For details, please refer to P.24)</p> <ul style="list-style-type: none"> ●Overload protection: Activated within approximately 5 seconds of the Motor load exceeding starting torque ●Overheat protection: Activated when the temperature of the heat sink inside driver exceeds approximately 80℃ ●Overvoltage protection: Activated when driving a load exceeding the permissible load inertia, or by coiling machine occasion ●Out of phase protection: Activated when the Motor cable is disconnected or feedback signal is disturbed by noise during operation. 			
Insulation resistance		100MΩ or more when 500V DC megger is applied between the AC power supply input terminal and the FG ground terminal, between the power supply input terminal and I/O terminal after continuous operation under normal ambient temperature and humidity			
Dielectric strength		Sufficient to withstand 1.8kV(3kV) at 60Hz applied between the AC power supply input terminal and the FG ground terminal (I/O terminal)for 1 minute after continuous operation under normal ambient temperature			
Ambient temperature & humidity		0~40℃,Max.85% RH(No corrosive gases or dust)			
Dimension(mm)		172(L)X123(W)X42(H)			
Weight(g)		950g			

3.2 Specs(120W、200W)(1/6hp、1/4hp)

Motor output		120W(1/6hp)	200W(1/4hp)	
Round shaft	AC110~115V	9B120S-1	9B200S-1	
	AC220~230V	9B120S-2	9B200S-2	
Pinion shaft	AC110~115V	9B120PD-1	9B200P-1	
	AC220~230V	9B120PD-2	9B200P-2	
Driver model	AC110~115V	DB120-1	DB200-1	
	AC220~230V	DB120-2	DB200-2	
Power input	-1 type (single phase) AC110~115V,50/60Hz	Max current	3.3A	4.9A
		Rated current	2.7A	4A
	-2 type (single phase) AC220~230V,50/60Hz	Max current	1.75A	2.8A
		Rated current	1.45A	2.3A
Starting torque(kgcm/Nm)		5/0.5	10/1	
Rated torque(kgcm/Nm)		4/0.4	8/0.8	
Permissible load inertia(GD ²)		23.99kgcm ²	112.81kgcm ²	
Min speed(r/min)		300	250	
Max speed(r/min)		3070	2500	
Speed regulation	To load	Max.±0.05(120W:3000r/min;200W:2500r/min, within no load~rated load)		
	To voltage	±0.05% (Power supply voltage ±15%,at 120W:3000 r/min with no load 200W:2500 r/min with no load)		
	To temperature	±0.05% (0~40°C ,at 120W:3000 r/min with no load 200W:2500 r/min with no load)		
Speed control		<ul style="list-style-type: none"> ●Controlled by external potentiometer(Variable resistor 20kΩ) ●Controlled by built-in potentiometer ●Controlled by DC voltage(0~5V) ●Work with D/A speed setter panel (Option) 		
Signal output/input		<ul style="list-style-type: none"> ●Photo coupler input ●Open collector output 		
Function		<ul style="list-style-type: none"> ●Zero point control ●Motor flat torque output ●Instantaneous brake ●SLOW START/SLOW DOWN ●Parallel operation ●Regenerated energy absorption protection : the function have to connect regenerative resistor, and it start operation at up down, coiling or inertial load operation 		
Protection function		<p>When the following are activated the alarm signal will be output and the Motor will come to a natural stop(For details, please refer to P.24)</p> <ul style="list-style-type: none"> ●Overload protection: Activated within approximately 5 seconds of the Motor load exceeding starting torque ●Overheat protection: Activated when the temperature of the heat sink inside driver exceeds approximately 80°C ●Overvoltage protection: Activated when driving a load exceeding the permissible load inertia, or by coiling machine occasion ●Out of phase protection: Activated when the Motor cable is disconnected or feedback signal is disturbed by noise during operation. 		
Insulation resistance		100MΩ or more when 500V DC megger is applied between the AC power supply input terminal and the FG ground terminal, between the power supply input terminal and I/O terminal after continuous operation under normal ambient temperature and humidity		
Dielectric strength		Sufficient to withstand 1.8kV(3kV) at 60Hz applied between the power supply input terminal and the FG ground terminal (I/O terminal)for 1 minute after continuous operation under normal ambient temperature		
Ambient temperature & humidity		0~40°C ,Max.95% RH(No corrosive gases or dust)		
Dimension(mm)		172(L)X123(W)X42(H)		
Weight(g)		980g(120W) ; 990g(200W)		

3.3 Product number code of driver

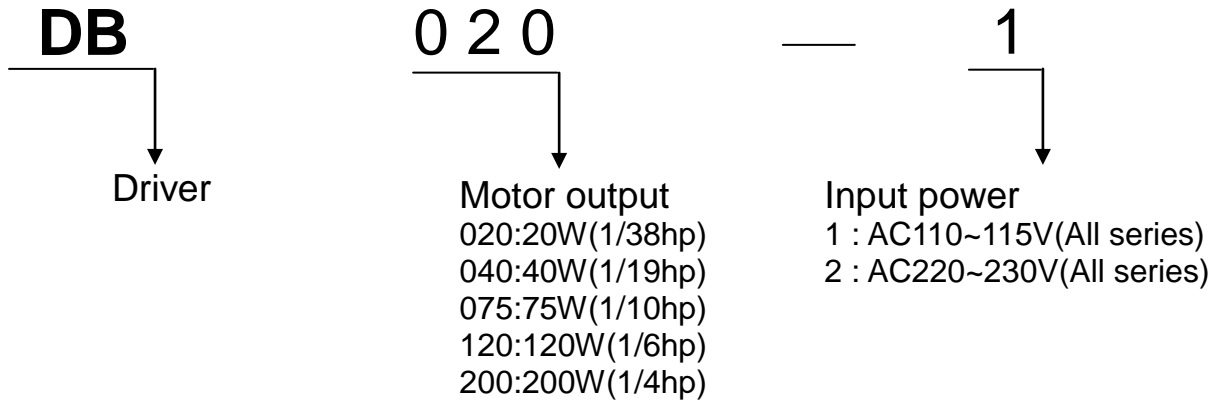

3.4 Product number code of Motor

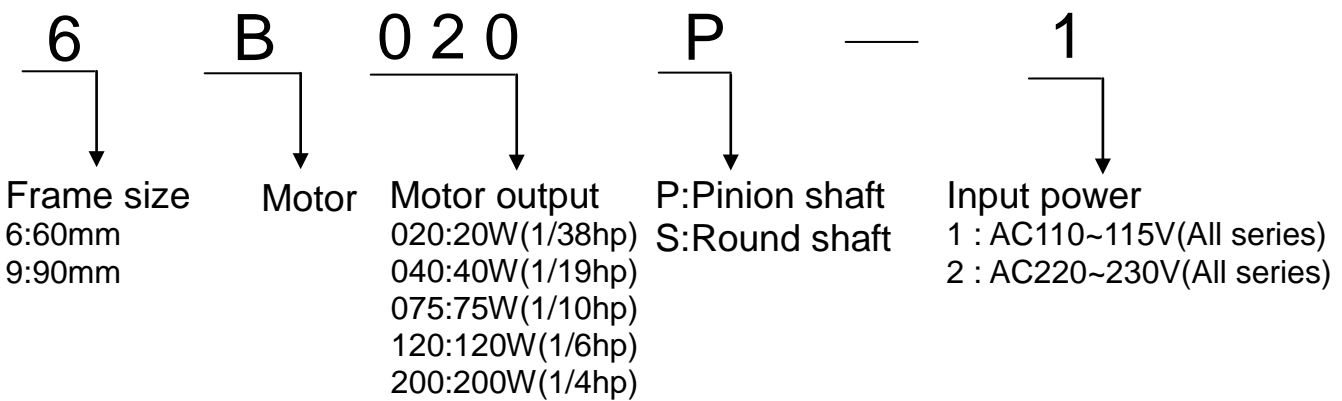

4.Names and functions of driver

4.1 Driver panel

LED Indicator

- 1.POWER:Power indicator
- 2.ALARM:Alarm indicator

Switch

- 3.+24/INT:Signal power supply switch

VR Adjustable Resistor

- 4.SPEED:Built-in potentiometer
- 5.SS:Potentiometer for acceleration
- 6.SD:Potentiometer for deceleration

Input/Output Contacts

- 7.+24Signal powersupply DC24V
- 8.EXT-VR: Speed potentiometer selectioninput
- 9.CW:Clockwise rotation input
- 10.CCW:Counterclockwise rotation input
- 11.SD:Slow stop/Instantaneous brake input
- 12.H:External speed control input
- 13.M: External speed control input
- 14.L: External speed control input
- 15.-COM:Ground terminal
- 16.S.O:Speed signal output
- 17.A.O.ALARM signal output
- 18.N.C:Not used

- 19.RG: Regenerative resistor connector(For 200W)(1/4hp);
No regenerative resistor connector below
120W(1/6hp)(included 120W)

MOTOR

- 20.MOTOR:Motor connector

Ground

- 21.FG:Frame ground

AC Power Input

- 22.L · N: AC power input

-1 type or -2 type driver panel

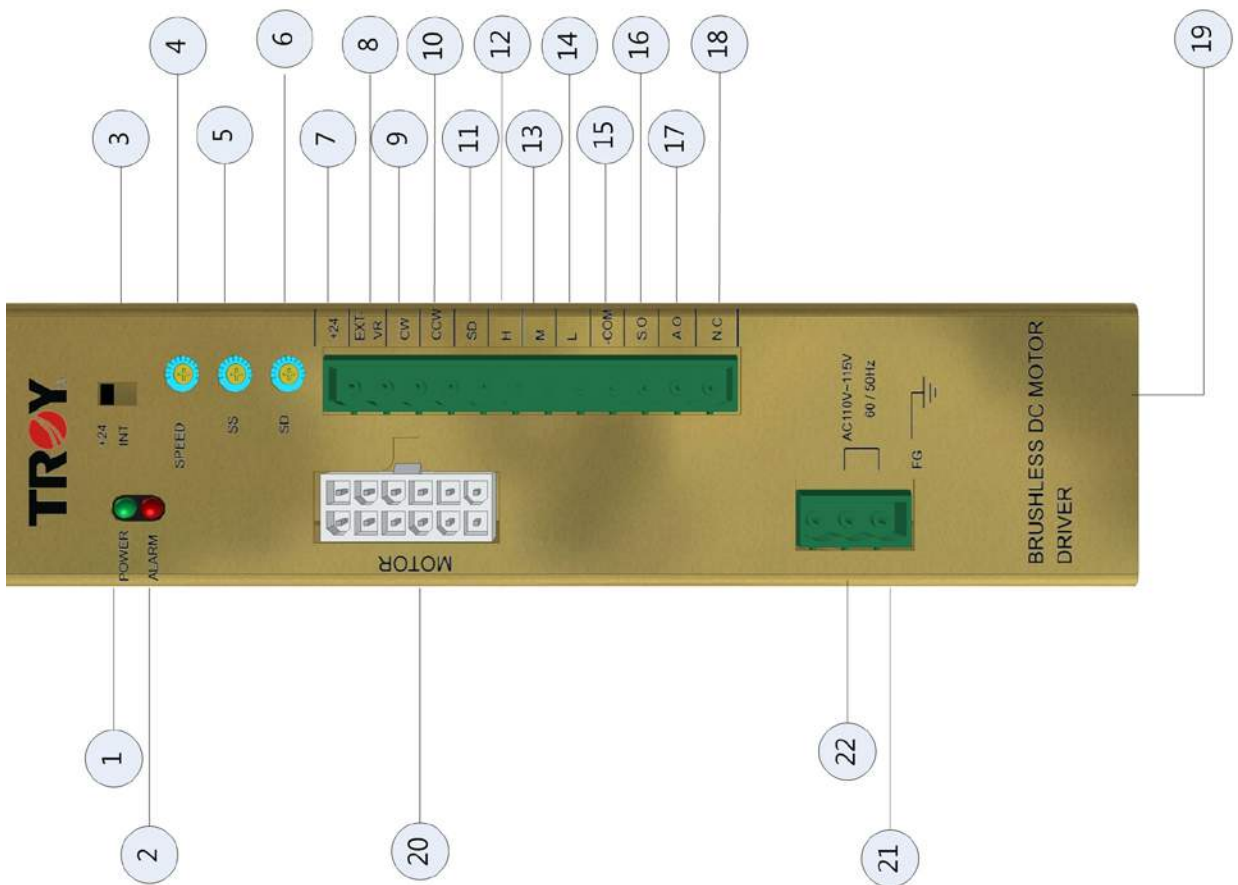

4.2 Functions of driver (20W~120W)(1/38hp~1/6hp)

No.	Display	Type	Names and functions	Functions	Factory settings
1	POWER	L	Power Indicator	Lights(green)when the power is ON	
2	ALARM	L	Alarm indicator	Lights(red) when a protection function is activated. (Over load · Over heat · Over voltage · out of phase)	
3	+ 2 4 I N T	SW	Signal power switch	+24: When controlling from the external power supply DC24V. Suitable for PLC control applications (Factory settings). INT: When controlling with a relay or switch(Driver built-in power supply DC24V)	Flip the switch to +24
4	SPEED	VR	Built-in speed potentiometer	Speed control range:300~3070r/min	Scale value 0 r/min
5	SS	VR	Potentiometer for acceleration	Analog setting:0.5~15sec	Scale value 0
6	SD	VR	Potentiometer for deceleration	Analog setting:0.5~15sec	
7	+24	I	Power supply for input signal	External power supply DC24V connect to this terminal	
8	EXT-VR	I	Speed potentiometer selection input	Input signal for selecting built-in or external speed potentiometer	
9	CW	I	Clockwise rotation input	Input signal for selecting CW rotation	
10	CCW	I	Counterclockwise rotation input	Input signal for selecting CCW rotation	
11	SD	I	Slow stop/Instantaneous brake input	When switching on, Motor will stop slowly according to SD set. When switching off, it will brake instantaneously.	
12	H	I	External speed potentiometer(H)	Used when controlling the speed by an external potentiometer or DC voltage(0~5V)	Variable resistor 20KΩ (Included)
13	M	I	External speed potentiometer(M)		
14	L	I	External speed potentiometer(L)		
15	-COM	I	Ground terminal	Common ground terminal for input/output signals and external power supply DC24V (For details, please refer to the P20.)	
16	S.O	O	Speed signal output	Used when monitoring the rate of rotation 12 Pulse/rev are output for each Motor rotation(For details, please refer to P.21)	

17	A.O.	O	Alarm signal output	This signal is output when a protection function (Over load · Over heat · Over voltage · Our of phase) is activated and motor comes to a stop	
18	N.C	—	Not used	No connection	
19	—	—	—	—	
20	MOTOR	I	Motor connector	Port for connecting the Motor cable	
21	FG	I	Frame ground	Power supply ground terminal	
22	-1 type (single phase) AC110~115V 50/60Hz	I	L,N power voltage input terminal	For AC power supply connection.	
	-2 type (single phase) AC220~230V 50/60Hz				

Type description: L→LED Indicator, SW→switch, VR→Variable resistor, I→Input , O→Output,
 —→No effect

4.3 Functions of driver (200W)(1/4hp)

No.	Display	Type	Names and functions	Functions	Factory settings
1	POWER	L	Power Indicator	Lights(green)when the power is ON	
2	ALARM	L	Alarm indicator	Lights(red) when a protection function is activated. (Over load · Over voltage · Over heat · out of phase)	
3	+ 2 4 I N T	SW	Signal power switch	+24: When controlling from the external power supply DC24V. Suitable for PLC control applications (Factory settings). INT: When controlling with a rely or switch(Driver built-in power supply DC24V)	Flip the switch to +24
4	SPEED	VR	Built-in speed potentiometer(Internal)	Speed control range:250~2500rpm	Scale value 0 r/min
5	SS	VR	Potentiometer for acceleration	Analog setting:0.8~15sec	Scale value 0
6	SD	VR	Potentiometer for deceleration	Analog setting:0.8~15sec	
7	+24	I	Power supply for input signal	External power supply DC24V connect to this terminal	
8	EXT-VR	I	Speed potentiometer selection input	Input signal for selecting built-in or external speed potentiometer	
9	CW	I	Clockwise rotation input	Input signal for selecting CW rotation	
10	CCW	I	Counterclockwise rotation input	Input signal for selecting CCW rotation	
11	SD	I	Slow stop/Instantaneous brake input	When switching on, Motor will stop slowly according to SD set. When switching off, it will brake instantaneously.	
12	H	I	External speed potentiometer(H)	Used when controlling the speed by an external potentiometer or DC voltage(0~5V)	Variable resistor 20KΩ (Included)
13	M	I	External speed potentiometer(M)		
14	L	I	External speed potentiometer(L)		
15	-COM	I	Ground terminal	Common ground terminal for input/output signals and external power supply DC24V (For details, please refer to the P.20)	

16	S.O	O	Speed signal output	200W:Used when monitoring the rate of rotation 24 Pulse/rev are output for each Motor rotation(For details, refer to P.21)	
17	A.O.	O	Alarm signal output	This signal is output when a protection function (Over load · Over heat · Over voltage · Our of phase) is activated and Motor comes to a stop	
18	N.C	—	Not used	No connection	
19	RG	R	Regenerative resistor connector	Consumed the regeneration energy	
20	MOTOR	I	Motor connector	Port for connecting the Motor cable	
21	FG	I	Frame ground	Power supply ground terminal	
22	-1 type (single phase) AC110~115V 50/60Hz	I	L,N power voltage input terminal	For AC power supply connection.	
	-2 type (single phase) AC220~230V 50/60Hz				

Type description: L→LED Indicator, SW→switch, VR→Variable resistor, I→Input , O→Output, R→Regenerative resistor

5. Installation

5.1 Installation conditions

Install the driver in a location that meets the following conditions:

- Indoors and nit exposed the direct sunlight
- Ambient temperature 0°C~40°C (no freezing)
- Ambient humidity 85% maximum (non-condensing)
- Not exposed to explosive, flammable or corrosive gas
- Place where heat can be dissipated easily
- Not exposed to continuous vibration or excessive impact
- Not exposed to environment of including radioactive materials, magnetic fields or vacuum
- When the driver is installed in an enclosed place or a place where a heating source exists nearby, please offering the excellent ventilation
- Area free of excessive electromagnetic noise (from welders, power machinery etc.)

Attached the noise filter or connected or power cable that can avoid the Motor faulty action because the noise

- Installing the multiple drivers, ensure to keep a space over 20mm between each driver.

5.2 Regenerative resistor & Speed potentiometer VR dimension (Attachment) Unit:mm

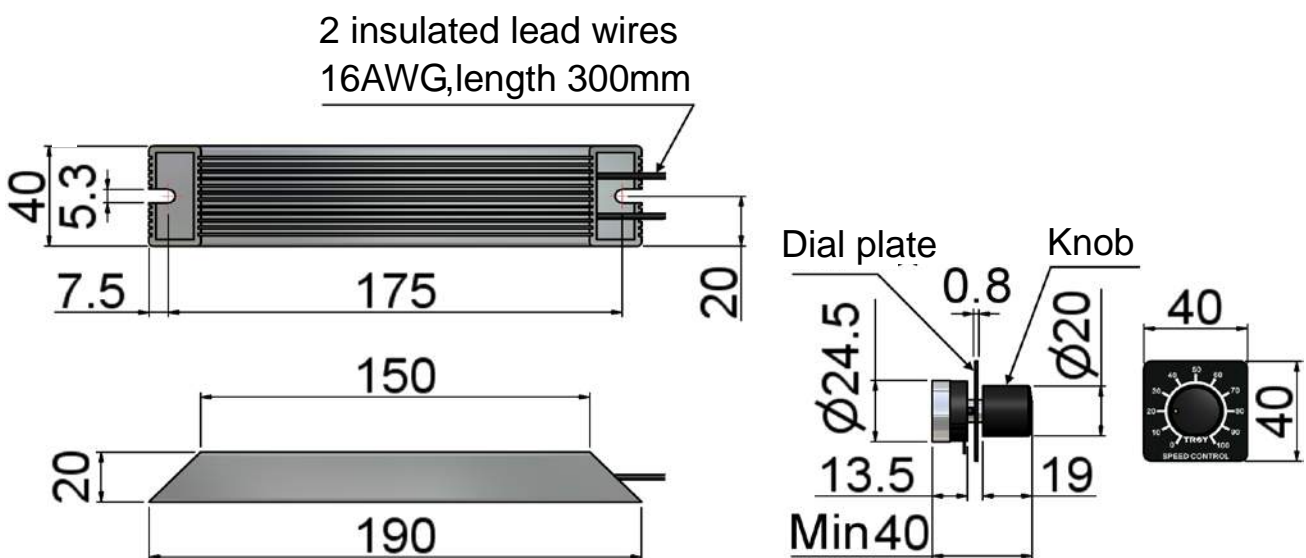

Brushless DC Motor Driver User's Manual

5.3 Driver dimension for 20W/40W/75W/120W (1/38hp,1/19hp,1/10hp,1/6hp) Unit:mm

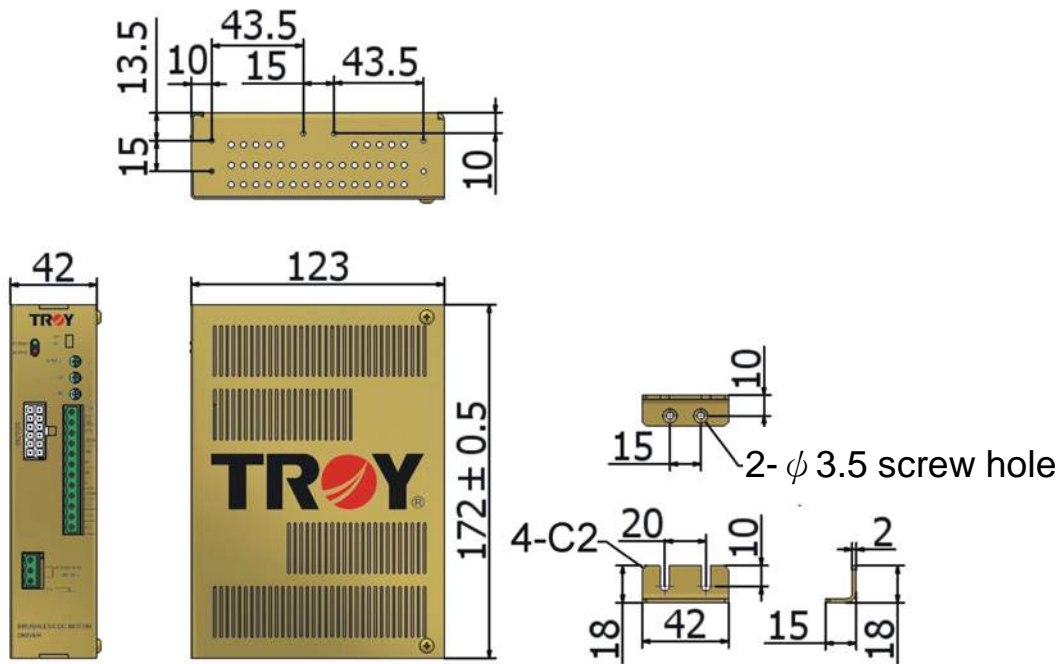

5.4 Driver dimension for 200W (1/4hp) Unit:mm

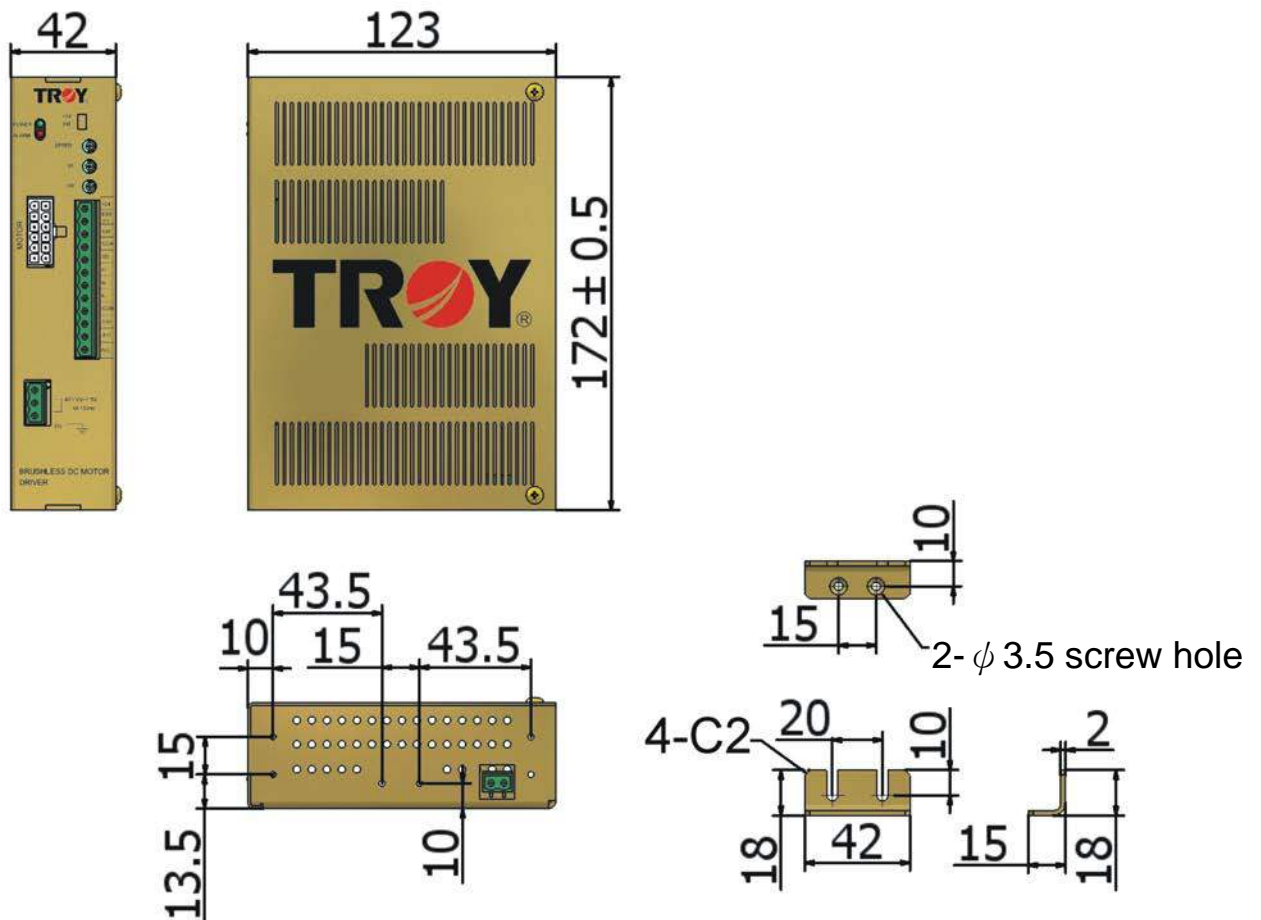

5.5 Driver installation

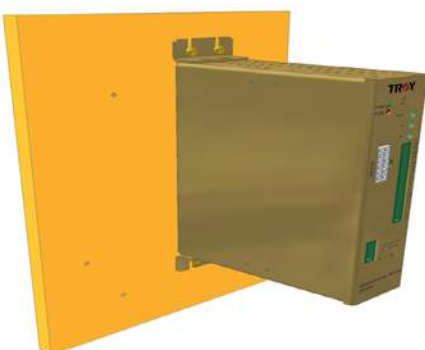
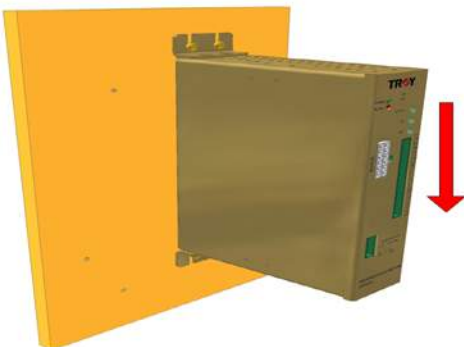

STEP1.

Use the mounting screws (M3X4pcs) included to connect the mounting bracket and driver.

STEP 2.

Please make mounting holes(M4-4 places) on the machinery and lock the 2 screws located under the driver without tightening.

STEP3.

Move up and down the driver, until the two screw holes on the top of the alignment, and take two M4 mounting screws

STEP4.

Complete the assembly of driver and check whether the driver has been locked or not.

■ Orientation

There must be a clearance of at least 25mm(1 in.) in the horizontal and vertical directions, respectively, between the driver and enclosure or the other equipment within the enclosure. When two or more drivers are to be installed side by side, provide 20mm(0.8 in.) clearance in the horizontal and vertical directions, respectively

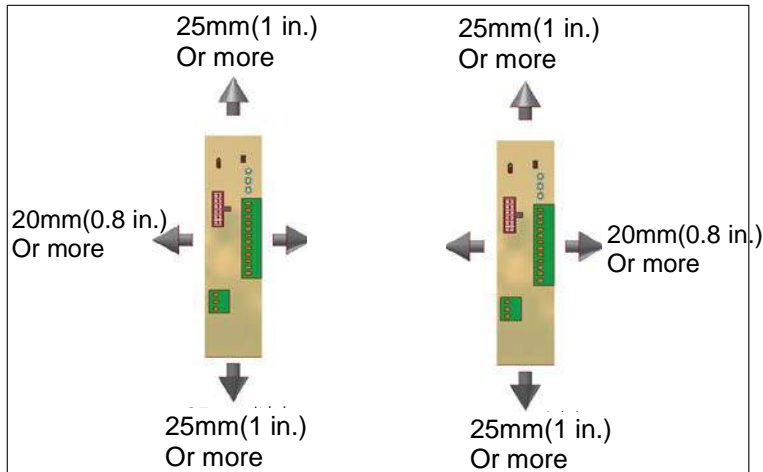

5.6 Regenerative resistor installation

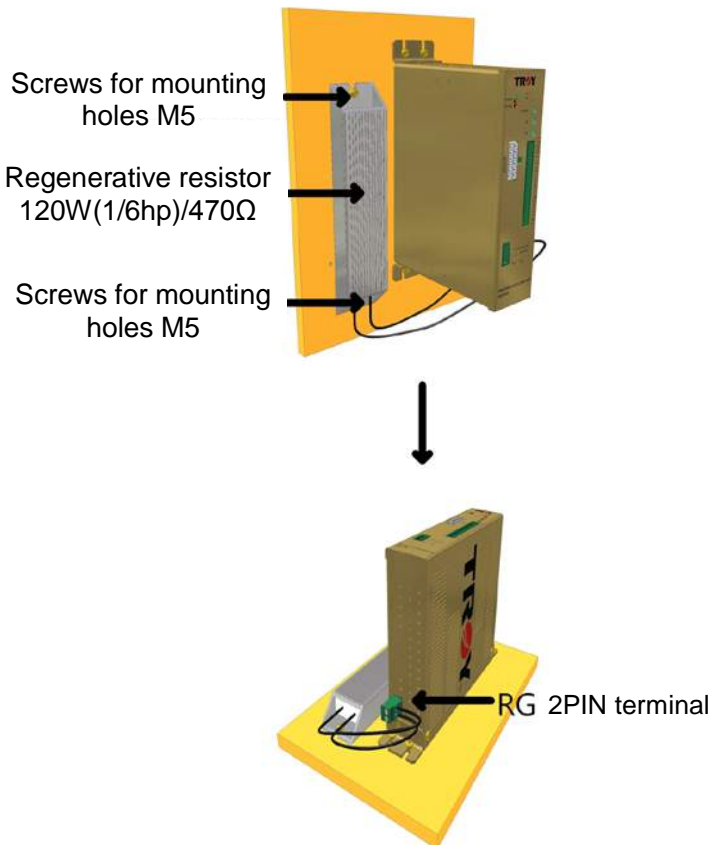

Step 1.

Making the 2 mounting holes for M5 screws(Not attached) then secure the regenerative resistor on the machinery that can have excellent heat conductivity

Step 2.

Connecting the insulated lead wires of the regenerative resistor to the driver's RG 2 PIN terminal

5.7 Driver connection

●Motor and driver connection

Please connect the Motor cable connector to the Motor connector. Before the connecting, please turn the power off first which can avoid driver damaged with the improper connection.

5.8 Precaution and specs for Motor extension cable

The Motor is connected to the driver using the extension cable (sold separately).The cable can be extended to a maximum of 10m. Please select the suitable extension cable according to the required length while ordering.

The total length of the cable from Motor to driver=Motor lead length 60cm+extension cable length.

Model	Length(m)
CB-010	1
CB-020	2
CB-030	3
CB-050	5
CB-070	7
CB-100	10

Contents of extension cables

- 1.Cable.....1pc
- 2.Plastic connector(Male).....1pc
- 3.Plastic connector(Female).....1pc
- 4.Metal connector PIN 12pcs each for male and female

※Actual cable length=Required length+10cm

●Plastic connector dimensions and pin layout

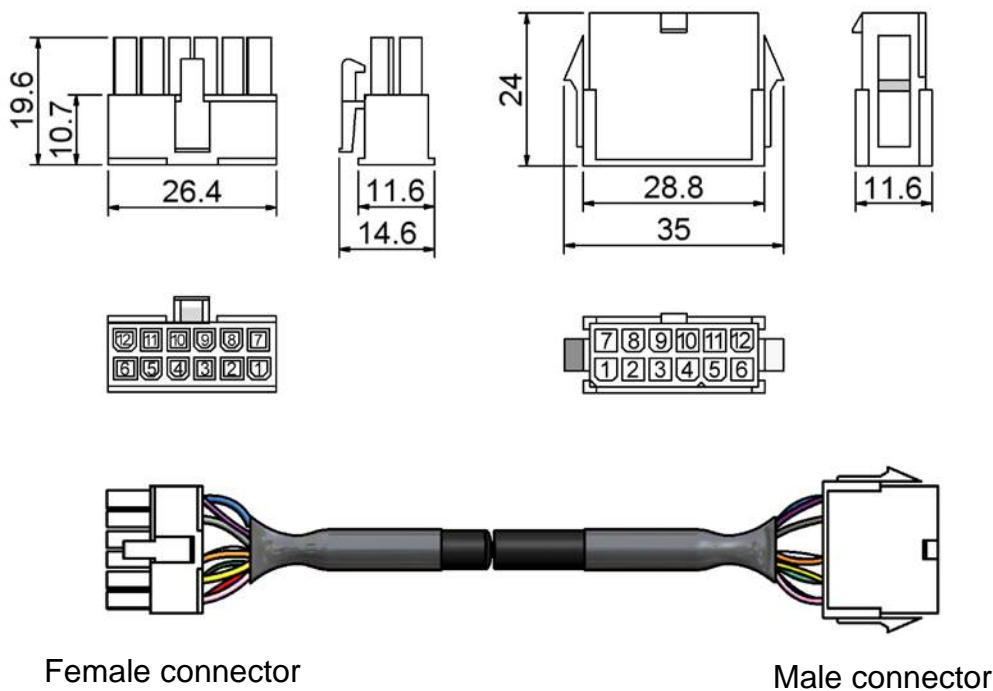

Pin and lead wire color table:

Pin No.	1	2	3	4	5	6	7	8	9	10	11	12
Lead Wire Color	Blue	—	—	—	Green	Red	Purple	Gray	—	Orange	Yellow	Pink

6.Connection

6.1 Precaution of signal input & output terminal connection

- Used a signal cable with metal shielded and the shielded wires please grounding single point.
Wire the power lines such as the Motor cable and power cable away from the signal cable by providing a minimum clearance of 10cm among them. Do not place the cable and power line in the same duct or pipe or bundle them together.
For more effective elimination of noise, use a shielded cable or attach ferrite cores if a non-shielded cable is used.
- When connecting to the PLC please confirm the definition of the contact for +COM(+24V、PNP transistor)、-COM(0V、NPN transistor). Please provide the proper input/output power voltage. Our contact is -COM type.
- Please use the terminals which provided and the terminals certificated by CE/VDE. When wiring, please affix the screws to their respective mounting places. Inappropriate installation may cause the bad connection and result the equipment damage.

6.2 Precaution for power supply connection

- a. The terminals for the power input which is certificated by CE&UL. When wiring, please connect the power lead to the female connector (Refer to each model's attachment) the insert the female connector to the power cable male connector.
Use a shielded cable of AWG18 (0.75mm²) in a diameter for the power cable.
- b. When wiring with the equipment running a large current (Such as high frequency、thermal coupler、electric welding machine、electrostatic、big power Motor etc.) Please refer to the system configuration. When power turns on, please turn on the equipment (running a large current) first then turn on the equipment running a small current. When power turns off, please turn off the equipment running a small current then turning off the high power equipment. It can make sure the safety for the power distribution.
- c. FG ground terminal on the driver must be connected with the FG ground terminal on the machinery.
Making it as short as possible. (Maximum of ground resistance is 100Ω.)

6.3 Wiring diagram

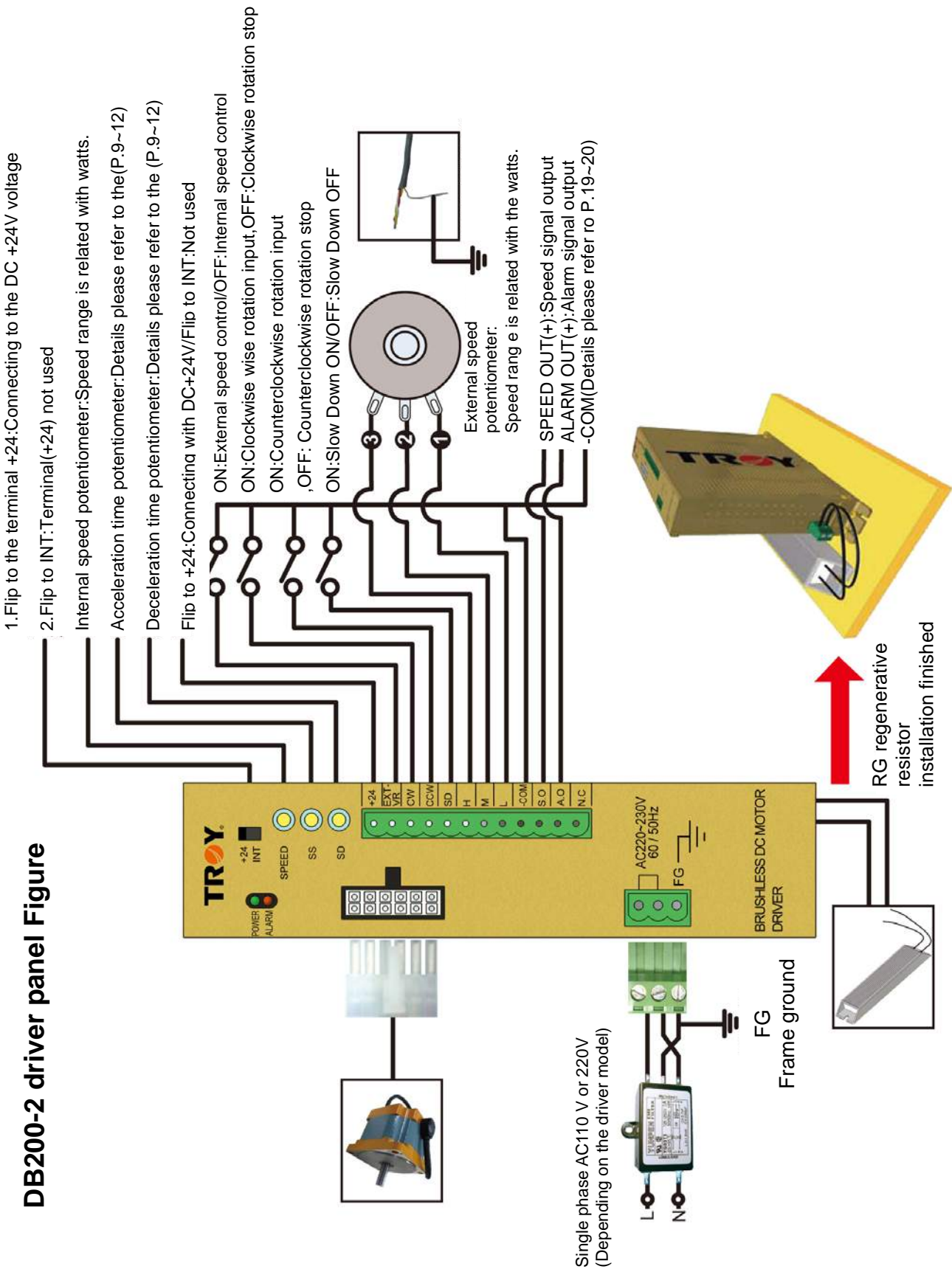

Brushless DC Motor Driver User's Manual

6.4 Signal input and output

● Input circuit

The input circuits function by means of photo coupler input, as shown in the diagram at right.

Input contacts as below:

EXT-VR

CW

CCW

SD(SLOW DOWN)

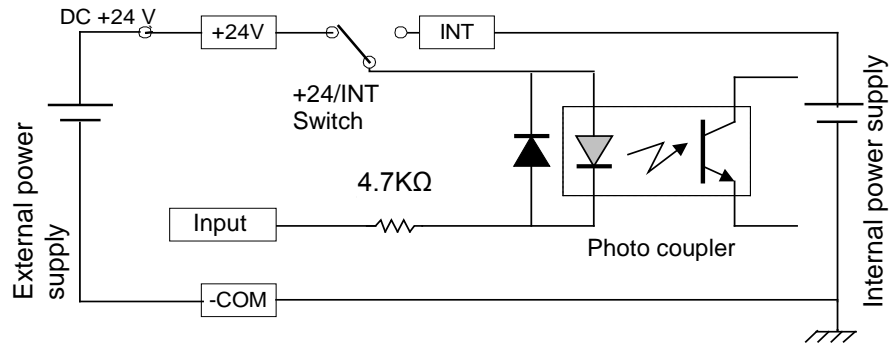

The working power supply for the input circuit shall be divided into the following:

Type	+24 / INT setting	Precautions
Driver built-in	Flip to INT	Because the DC power inside the drive supplies the voltage for the connection, the DC+24V connection is not necessary to avoid Motor exceptions. <u>This is suitable for the applications using a single driver.</u>
External DC power	Flip to +24	As the external DC power supplies the voltage required for the connection action, please connect DC+24V to Contact (+24) and GND, to Contact (-COM). Please keep the DC power as stable as possible to avoid noise interference and Motor exception. <u>This is for the applications using other controllers (e.g. PLC, PC, etc.) for system control.</u>

● Examples of input signal connection

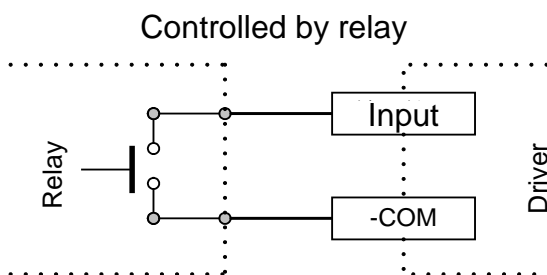
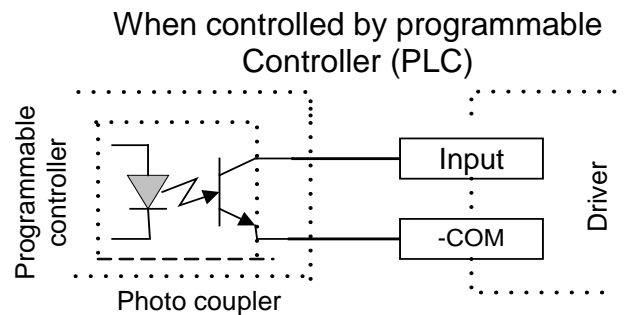
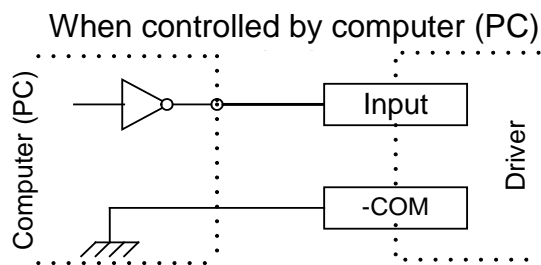

※Using the transistor output type contact module which can prevent the sparks interference and cause the faulty operation

Brushless DC Motor Driver User's Manual

●Output circuit

As shown in the diagram at right, the open collector transistor is used for the output circuits which require external power supply. This power supply should be offered in DC26V or less. Also connect a limiting transistor (series connection) suitable for the power supply voltage to keep the current from exceeding 10mA.

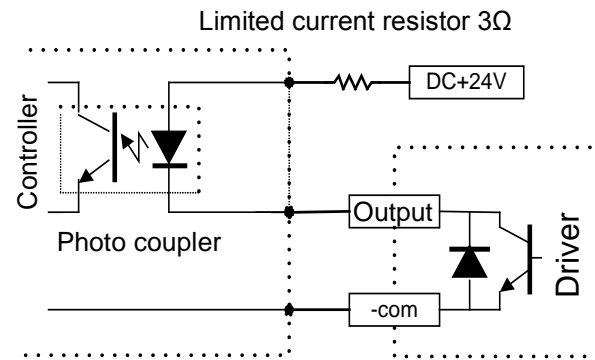

The output contacts as below:

S.O.(SPEED OUT)

A.O.(ALARM OUT)

●Output circuit connection

S.O.(SPEED OUT)Speed signal output: Signal output type is digital pulse signal and pulse width is around 0.6 msec with negative logical(Active”L”) output. It is output a rate of 12 pulse/rev per Motor rotation for 20W~120W(1/38hp~1/6hp) Motor. It is output at a rate of 24 Pulse/rev per Motor rotation for 200W (1/4hp) Motor.

Motor rotation can be calculated with the following formula:

$$\text{Motor speed [r/min]} = \frac{\text{Speed output frequency [Hz]}}{\text{Output pulse numbers}} \times 60$$

A.O.(ALARM OUTPUT): This signal is output when one of the driver's protection Functions (Over heat, over voltage, overload, out of phase) is activated. Signal output by negative logical (Active”L”) and the ALARM indicator lit up(Red).

7. Operation

7.1 Operation mode setting

● Mode table for signal input

Signal input		CW input	CCW input	SD input	EXT-VR input
Operation mode					
Instantaneous CW/CCW rotation		ON	ON: Instantaneous CCW rotation OFF: Instantaneous CW rotation	OFF	—
Slow start Slow down	CW rotation	ON: Slow start OFF: Slow down	OFF	ON	—
	CCW rotation	OFF	ON: Slow start OFF: Slow down		—
Slow start Instantaneous brake	CW rotation	ON: Slow start OFF: Brake	OFF	OFF	—
	CCW rotation	OFF	ON: Slow start OFF: Brake		
2 selections of speed input	Internal speed	—	—	—	OFF
	External speed				ON

1. The ON in the chart is input contact, input “L” level and connect to the contact(-COM)
The OFF in the chart is input contact, input “H” level is the unused condition.

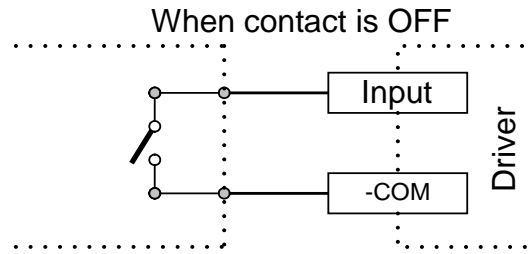
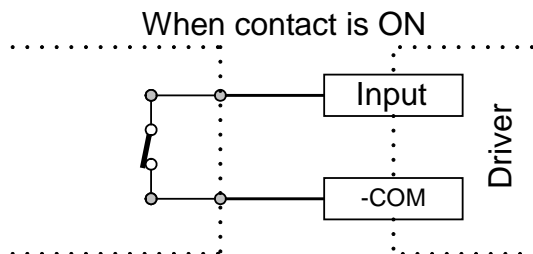

2. CW and CCW input contact: If CW and CCW are inputted simultaneously, CCW has priority. So Motor rotated counterclockwise.
3. SD input contact: When SD input is turned on; the Motor slows down and comes to a stop. As the SD input is turned off, the Motor can be stopped instantly. When it needs to brake during deceleration, you can turn “on” to “off” situation.
4. Instantaneous brake : When SD input is turned off, the Motor can be stopped instantly. But the Motor won't stop right away because the inertia of the load. Different load and the over rotation will be different , also the driver will following the Motor internal speed feedback signal and continuous the stop until Motor stop completely.

(The time of instantaneous brake will be different from the load condition)

Brushless DC Motor Driver User's Manual

5. EXT-VR input contact: 2 selection of speed input

ON: Speed can be changed by selecting external speed potentiometer(VR)

OFF: Speed can be changed by selecting built-in speed potentiometer(Regulating the speed by SPEED knob on the driver's panel)

This connection can work with the SD input connection setting and SD, SS setting time to achieve 2 selections of speed switching more smoothly. The control program co-ordination of every input contact and Motor operation situation, please refer to the following the operational timing chart.

●Operational Timing chart

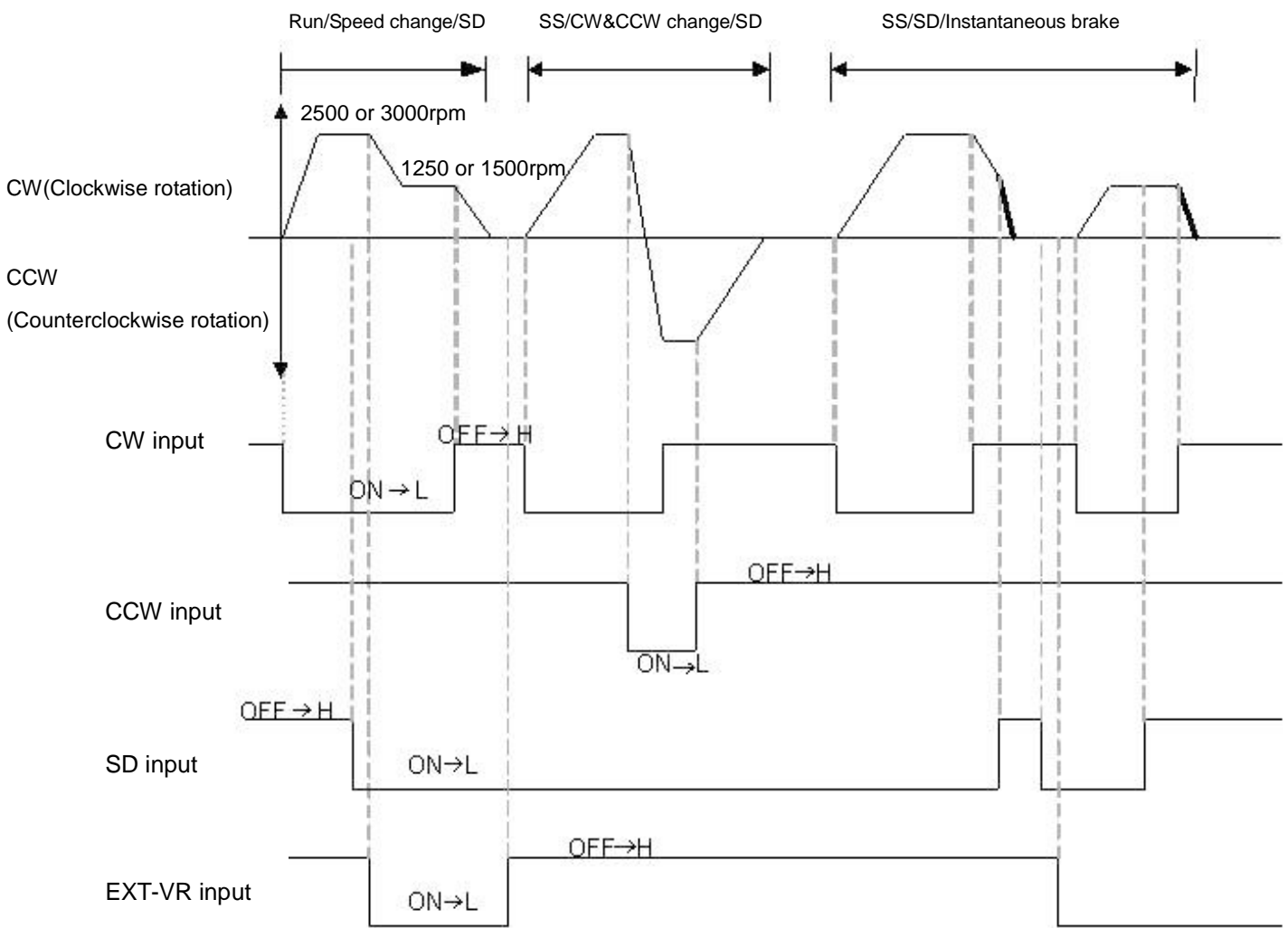

The “ON →” Input contact and input “L” level; that is, connecting to the contact (-COM).

The “OFF →Input contact and “H” level input; namely, not used.

Note: Do not control the Motor RUN&STOP by 「power switch」 when the power turns on and the Motor runs at the same time. The surge current will cause the damage.

7.2 Protection functions

●Driver has the protection functions as below:

Protection function	Number of ALARM LED blinks	Possible causes	Remedial action
Motor protection	1	<ol style="list-style-type: none"> 1.Motor cable not connected 2.Motor cable broken 3.Motor HALL SENSOR components damaged or disconnected 4.Motor HALL SENSOR feedback signal line contact failure or is spoilt by interference and have abnormal condition 	<ol style="list-style-type: none"> 1.Insert the Motor cable connector then reset the power 2.Change a new Motor then reset the power 3. If the cause is 3, please change a new Motor then reset the power 4. If the cause is 4,please check whether the power cable wiring is stable or spoilt by interference from external noise (ex:high frequency, thermocouple, ultrasound, power equipment...etc)
Out of phase protection	2	<ol style="list-style-type: none"> 1.Bad connection for U,V,W leads or Motor cable broken 2.Collider 3.Motor shaft is restrained by abnormal conditions 	<ol style="list-style-type: none"> 1. If the causes are 1, Please change the Motor and reset the power 2. If the cause is 2,3, please check if the mechanism has the condition like collider or Motor shaft is restrained by abnormal conditions
Overheat protection	3	Activated in the occasion of the ambient temperature exceeds 40°C , and also the temperature of the heat sink inside driver exceeds approximately 80°C since Motor start/stop/CW/CCW in the short cycles.	<ol style="list-style-type: none"> 1. When the ambient temperature exceeds the 40°C .Use the appropriate cooling method to reduce ambient temperature. 2.Please confirm the load torque or operation cycle under 40°C
Over voltage protection		<ol style="list-style-type: none"> 1. Activated when driving a load exceeding the permissible inertia. When Motor stop ,the Motor shaft rotated by inertia and generated the regeneration power 2. Using in the applications of vertical and horizontal and generated the regeneration power. When Motor stops instantaneously, it will generate the regeneration power 3. The high voltage is transient when the power is ON 	<ol style="list-style-type: none"> 1.If the causes are 1,2,please attached regenerative resistor or adjust the SS/SD to consumption or lower down the opportunity for regenerative voltage 2. If the cause is 3, please install the power stabilizer and surge protector to eliminated the high voltage from the power input
Over load protection	4	Activated within approximately 5 seconds of the Motor load exceeding rated torque or Motor doing CW/CCW rotation, start/stops being repeated in short cycles	<ol style="list-style-type: none"> 1. If exceeding the rated torque, please reduce the load torque. 2.If within the rated torque, please extend the operation cycle.
Instantaneous over current protection		Activated when big power system parallel and turn ON the power at the same time	Turn on the equipment running a big current first then a small current. Turn off the equipment running a small current first then a big current.

7.3 ALARM resetting:

Interference : When ALARM protections activated and the problems cannot be solved .It may cause by interference.

Judgement methods : When the driver has ALARM condition, please handle the condition by the methods : Motor protection, out of phase protection, over heat protection, over voltage protection, over load protection, instantaneous overcurrent protection. If the condition is still not being released, the ALARM condition may be caused by interference.

Release : Checking the interference is entered via power source terminal or control signal terminal. If interference is happened from the power source terminal, attached the noise filter at the power source terminal. If the interference is happened from the control signal terminal, attached the spark extinguisher at the control signal terminal or operated the control voltage individually.

※If the problem cannot be solved by it, contact to your local seller

7.4 Noise prevention

Noise interference channel	Preventive measures
Output/Input signal lines	<ol style="list-style-type: none"> 1.Keep the signal lines as short as possible (please keep the line length below 2m) and separate power lines at least 30 cm from any cable running a large current. 2.When setting the speed by external speed potentiometer(VR) or a DC voltage, use the signal line provided with the unit.
Feedback signals between Motor and driver	<ol style="list-style-type: none"> 1.Motor connected with driver by a cable. If there is necessary for long distance connection. Please use the extension cable (sold separately) that can make sure the connection is no problem. 2.Place Motor cable at least 30cm away from any cable running a large current.
Power supply lines	<ol style="list-style-type: none"> 1.Supply the driver with a separate AC power. Do not share the power supply for those devices with radiating noise sources (e.g. High frequency, ultrasonic, welder or thermo coupler etc.)If necessary please install the “No fuse braker”(NFB) to prevent the surge current 2.For the F.G. connection on the driver, use the type 3.It is grounding with short-distance and coarser diameter wires. 3.Install a noise filter in front of the AC power input to shield off external noise interference.

7.5 The meaning of ALARM protection functions

When ALARM LED is flashing which means ALARM protection functions activated and try to take an appropriate measure according to the table of the driver's protection functions.

If you cannot solve the problems and you can tell the local seller the numbers of ALARM LED blink which can help the local seller report to the engineer. The engineer will offering the solutions to you according to your information.

Brushless DC Motor Driver User's Manual

7.6 Parallel operation/Multi-speed control/Voltage control

●Using the external speed potentiometer

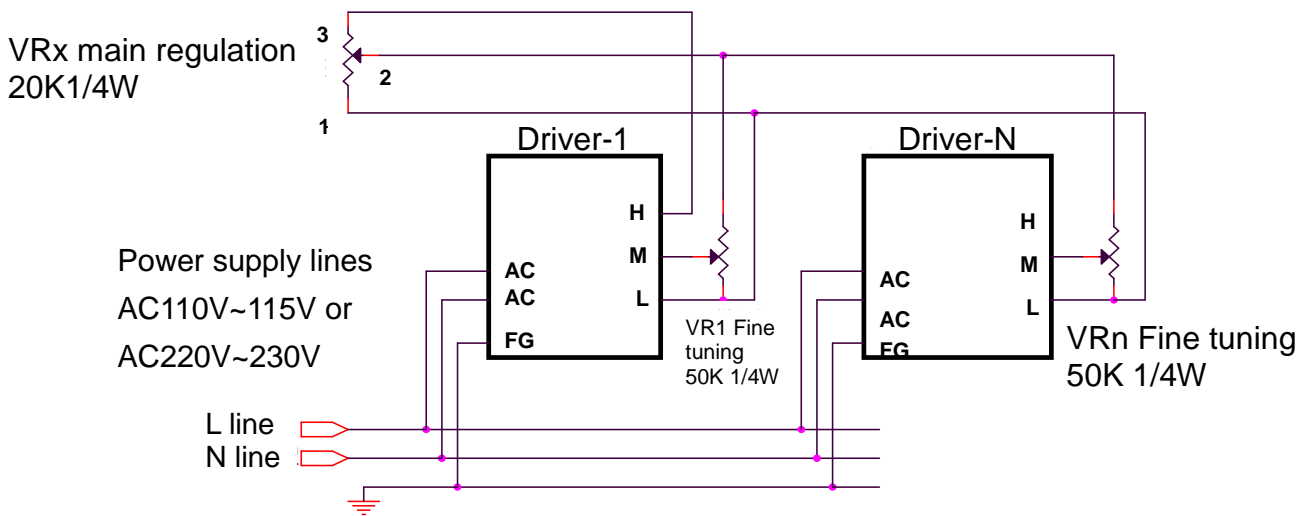

●Using a DC power supply

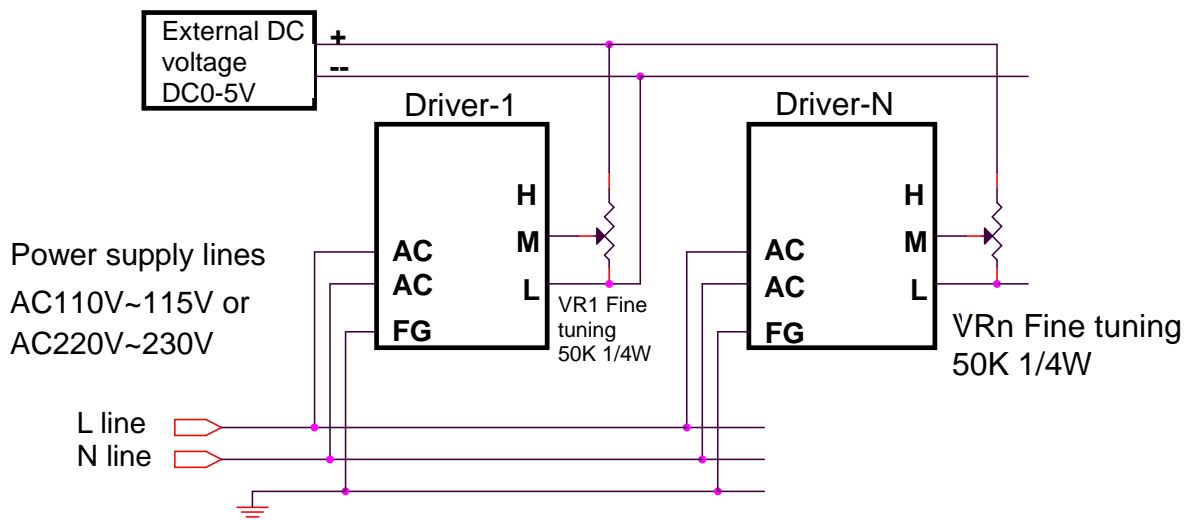

Using a DC power supply		Using a external speed potentiometer	
DC voltage setting range	DC0~5V	Main regulation VRx	20(KΩ) 1/4W
DC current capacity	1mA/pc		
Driver-1 VR1 fine tuning	50KΩ 1/4W	Driver-1 VR1 fine tuning	50KΩ 1/4W
Driver-N VRn fine tuning	50KΩ 1/4W	Driver-N VRn fine tuning	50KΩ 1/4W

1. 「N」 is the number of drivers. No more than 20 drivers should be operated simultaneously when using the external speed potentiometer.
2. Motor speed differences can be adjusted by connecting the fine tuning resistance VR1 & VRn.
3. Please connect the other input/output lines to each driver individually.

●Multi-speed control

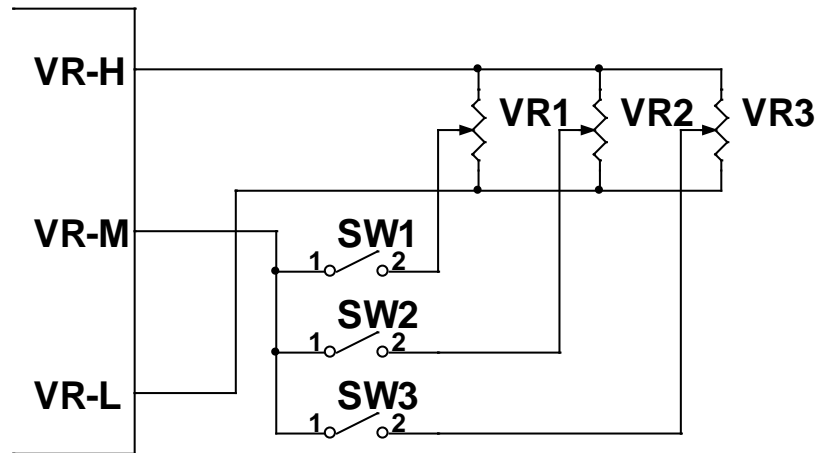

Three kinds of speed switch control			
SW3	SW2	SW1	Resistance value
OFF	OFF	ON	VR1
OFF	ON	OFF	VR2
ON	OFF	OFF	VR3

Note:

1. It is recommended to use 20KΩ variable resistor for VR1, VR2 and VR3 (Min.10KΩ).
2. The greater resistance value and the greater voltage so the speed will get fast
3. If there need 3 selection speeds control please contact with the nearest seller.

●Using a external power supply

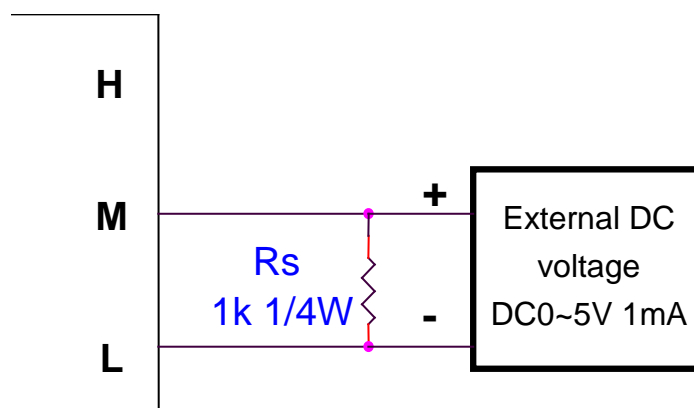

Note:

1. The external DC power output must be connected in parallel with the Rs resistor 1KΩ, 1/4W.
2. Please use the output-insulating DC power supply with ∞ output impedance.

7.7 DC voltage-speed characteristics (2500r/min)

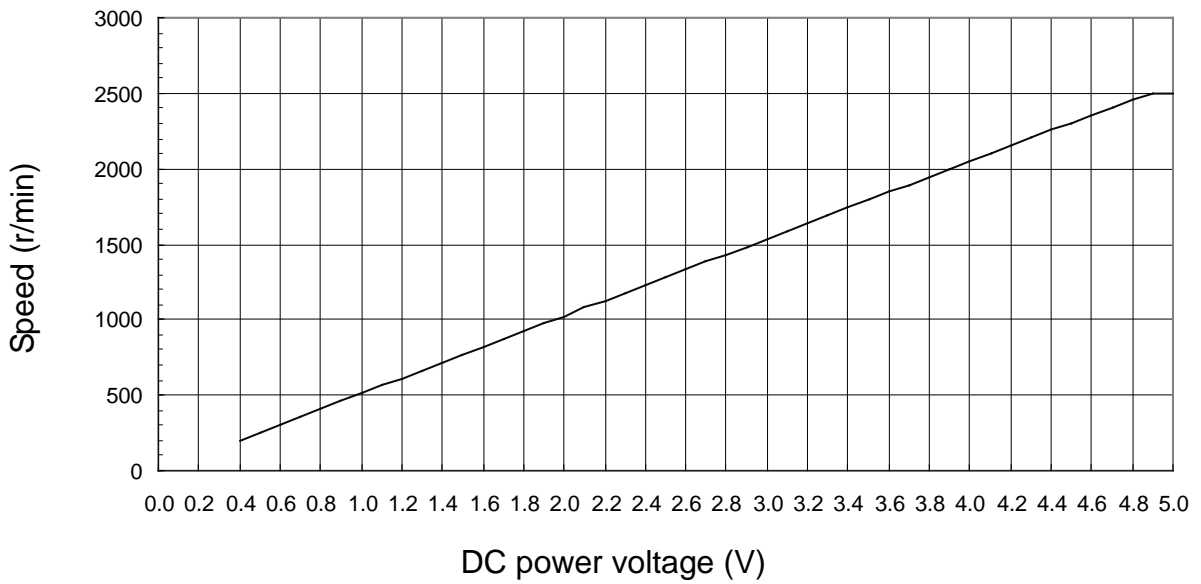

7.8 Speed potentiometer dial scale-speed characteristics (2500r/min)

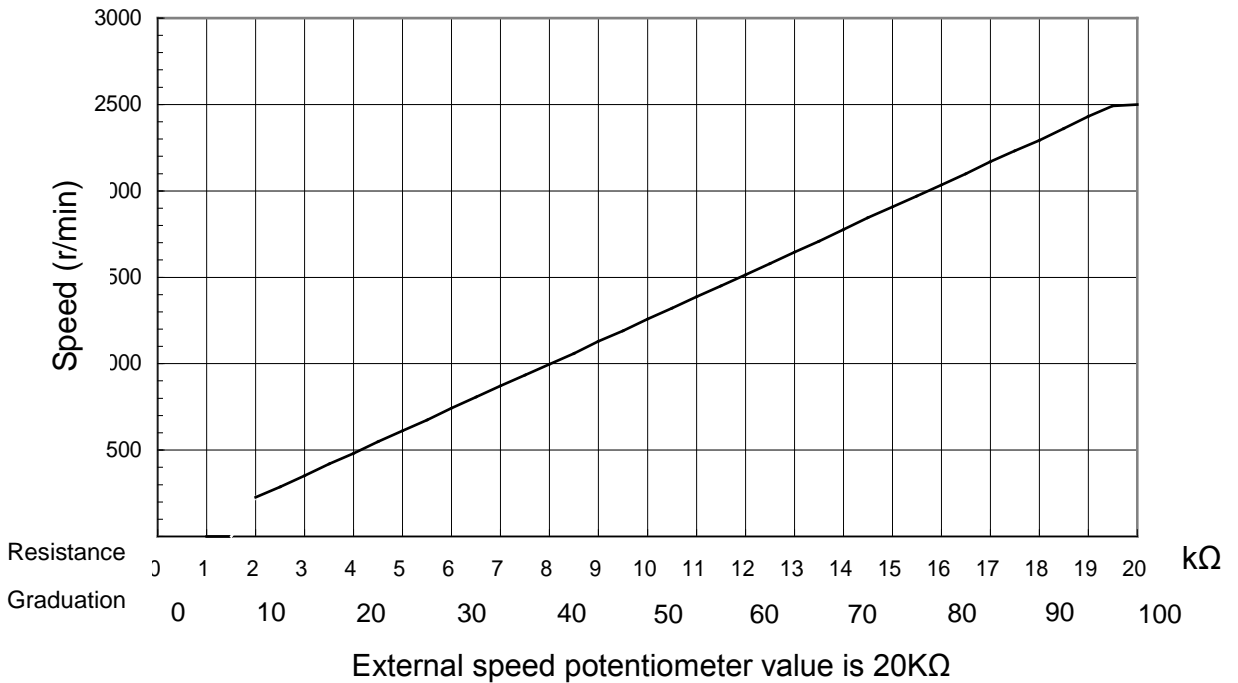

7.9 DC voltage-speed characteristics (3000r/min)

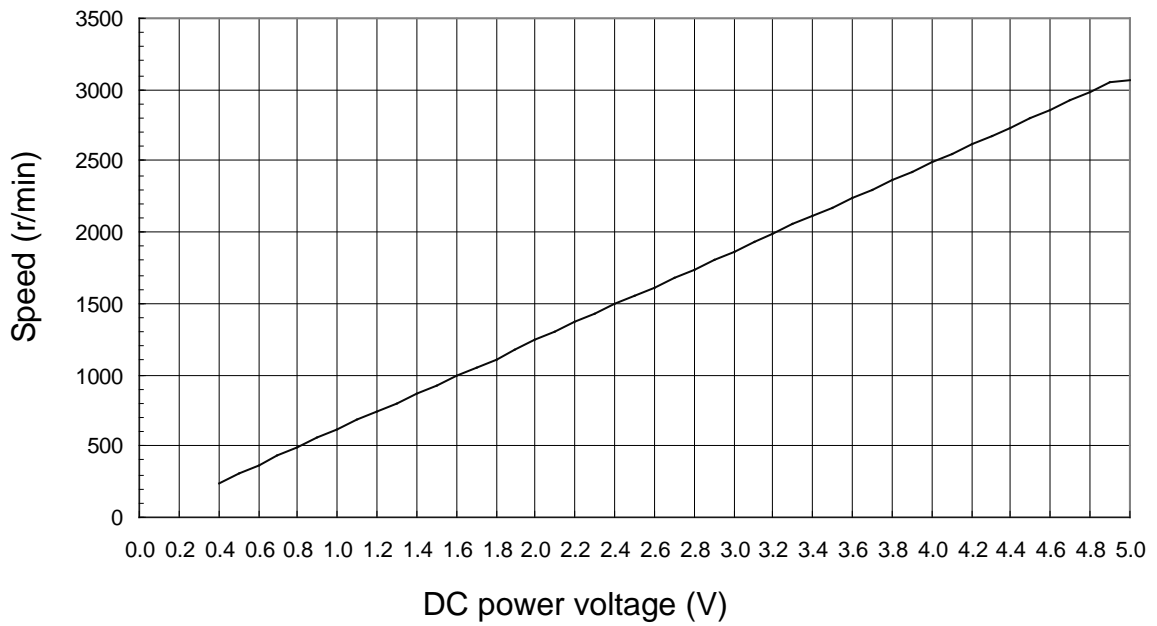

7.10 Speed potentiometer dial scale-speed characteristics (3000r/min)

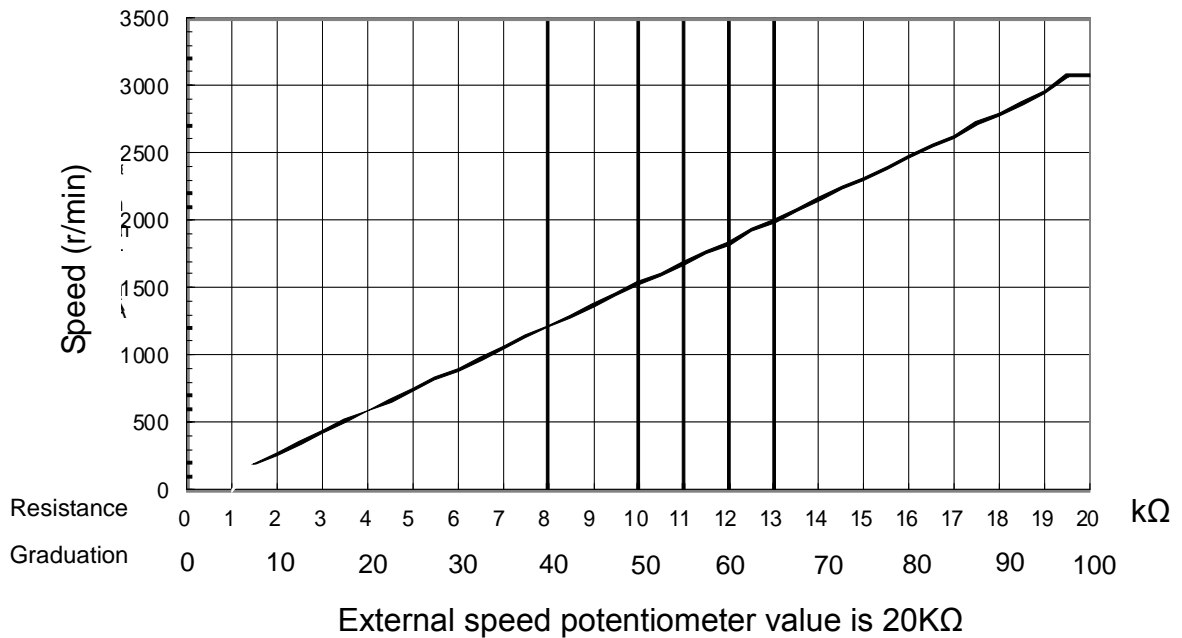

8. Before using

1. Cautions of power

- ※ Please confirm the product's power specs first then connected to the proper power. Power cable is not attached.
- ※ Please turn off the power in advance which connected to the driver.
- ※ Please checking the Motor cable's connector when input the power. The bad connection will cause the faulty action or damage.
- ※ Do not insert or pull out the Motor's connector when driver is electrify.

2. Cautions of driver

- ※ When adjusting the speed by external potentiometer or DC voltage please using the noise insulated signal cable(attachment) that can prevent the external noise to cause the faulty action. Shielded cable connected to –COM terminal.
- ※ Please make sure the polarity of the DC power when adjusted the speed by DC voltage.
- ※ When Motor running in CW/CCW direction, start and stops frequently in short cycles. Please mention that temperature of Motor not exceeds the 90°C and the heat sink inside driver not exceeds 80°C. If the temperature of the heat sink inside driver over 80°C, the overheat protection will activated and Motor will stop running.
- ※ Please make sure the ambient temperature and condition(Water, oil, dust, corrosive and flammable gas) making the proper protection.

3. Do not disassemble the Motor or driver

- ※ Do not disassemble Motor or driver personally. We won't take any responsibility for it.

* For environment protection, paper saving and resources preservation, please download the user's manual directly from TROY website : [http:// www.troy.com.tw](http://www.troy.com.tw)

※ **Environmental Responsibility**

- TROY is always committed to environment protection. All packaging material is recyclable and reusable.
- If disposing of used product, please recycle by type as per waste disposal procedures.

-----Protect the green earth with your care and commitment-----

※ The product is subject to design modification for performance improvement without prior notice. For more details, please contact with your local seller.

TROY TROY ENTERPRISE CO., LTD

Professional manufacturer

Website : www.troy.com.tw

E-mail: sales@troy.com.tw

TEL : +886-2-2299-9839



ISO9001:2015



ISO14001:2015

