

TUD31/TUD32

Induction Motor Speed Controller

Indicated Type

User's Manual

Environment Responsibility

- TROY is always committed to environment protection. All packaging material is recyclable and reusable.
- If disposing of used product, please recycle by type as per waste disposal procedures.
-----Protect the green earth with your care and commitment-----

※The product is subject to design modification for performance improvement without prior notice. For more details please contact your local seller.

Precautions

Precautions for using

1. Thank you for purchasing TROY products. Please read this user's manual thoroughly before installing and operating the driver, and always keep the manual where it is readily available.
2. The products described in this manual has been designed and manufactured for use in industrial machinery, and must not be used for any other purpose. We are not responsible for any damage caused through failure to observe this warning.
3. Check that the motor, driver and any accessories are all present. If an accessory is missing or damaged, contact the nearest our branches.
4. Never disassemble the motor and driver. Damage or performance impairment may result. Disassembly voids all warranties.

Precautions for maintenance

Check the ambient environments, clean the system equipment to remove dust and tighten the screws periodically. Also pay attention to the followings.

1. Contact us when repairs become necessary.
2. Since the temperature of the frame of the driver can rise high, be careful when conducting maintenance work or inspection work.

Precautions for warranty period

Within the period of one year after delivery of the system equipment, when failures occurring from design error or fabrication error attributable to the manufacture side occur, we will be repairing the failure free of charge within the reparable range or will replace with substitute. (We cannot hold ourselves responsible for breakage and accidents occurring from your use beyond the specified range described in this document.)

Precautions for disposal

When disposing of the driver and the motor, treat them as ordinary industrial waste.

Content

1.Specifications.....	1
1.1 Specs.....	1
1.2 Controller of product number code.....	1
1.3 Attached motor of product number code.....	1
2.Verifying the accessories.....	2
3.Names and functions of controller.....	2
4.Connection and operation.....	5
4.1 Wiring diagram.....	5
4.2 Operation.....	5
4.2.1 Operation procedures.....	5
4.2.2 Electro-gear ratio setting.....	6
4.2.3 Cautions of operation.....	8
4.2.4 Cautions of CW/CCW.....	8
4.2.5 Motor connection.....	8
4.2.6 Extension cable specs.....	8
5.Installation.....	9
5.1 Starting capacitor installation.....	9
5.2 Controller installation.....	11
6.Dimension.....	13

※For any operational or technical question with the product, please contact us during our business hours.

1.Specifications

1.1Specs

Controller model	TUD31	TUD32
Drive current	3A	
Input power	Single phase AC100~115V -15%~+10%	Single phase AC200~230V -15%~+10%
Drive motor power	< 90W	
Speed regulation	50Hz : 90~1400r/min 60Hz : 90~1700r/min	
Functions	Speed control 、 Instantaneous brake stop 、 Slow start 、 Slow stop 、 Speed display 、 Electro-gear ratio setting	
Insulating resistance	When tested with DV500V high resistance tester and resistance between F.G. and power terminal is over 100MΩ	
Insulating voltage	No abnormal symptoms when supplying 3KV/60Hz voltage between F.G. and power terminal for 1 minute	
Ambient temperature	0~40°C	
Ambient humidity	Within 85%RH	
Dimension(mm)	100(L)×60(W)×99(H)	
Weight	192g	

1.2Controller of product number code

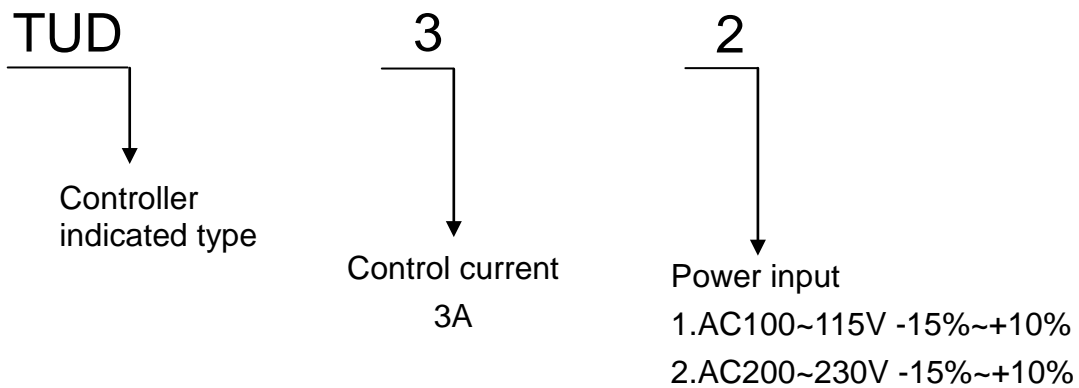

1.3Attached motor of product number code

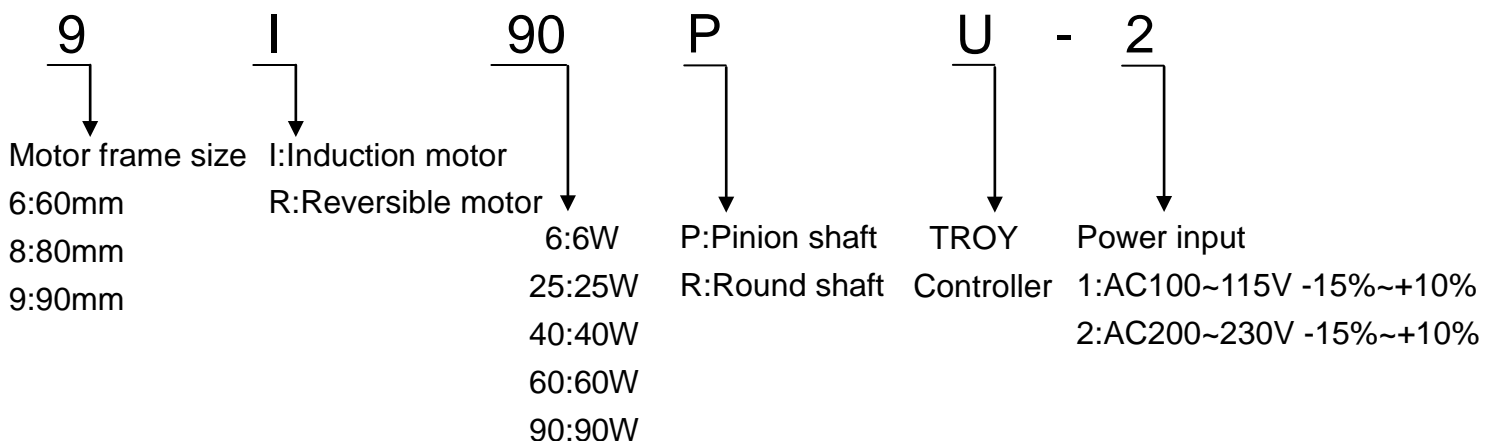

2. Verifying the accessories

Check that the following items and any accessories are all present. If an accessory is missing or damaged please contact to the local seller.

Item	Quantity
Controller	1
Connector(2 PIN)	1
Connector(6 PIN)	1
Extension cable(1m)	1
Ground screws	1
Mounting screws for starting capacitor	1
Connecting wires for starting capacitor	2
User's manual	1

※The starting capacitor provided with motor package, our controller applied to 6W~90W motor, so the starting capacitor didn't provided with controller. Please make sure the starting capacitor is conformed to the motor or not.

3. Functions of driver part

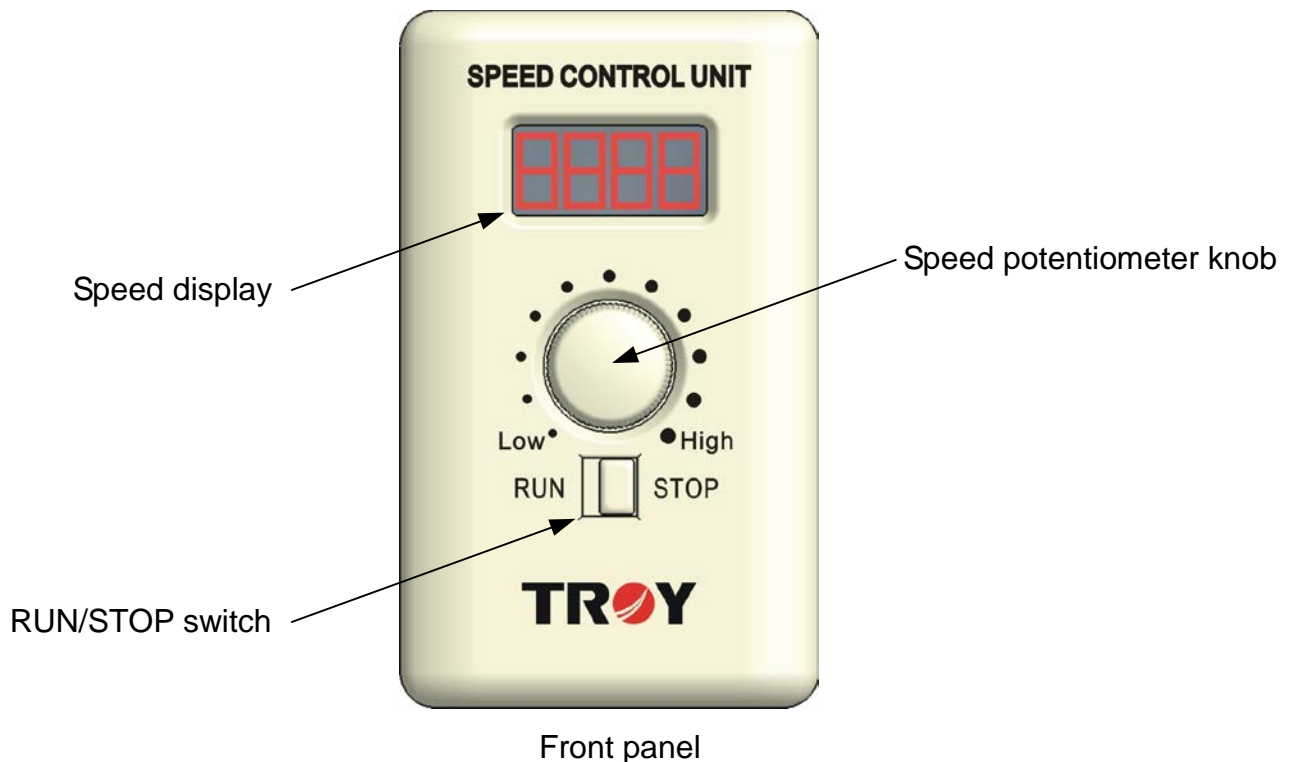

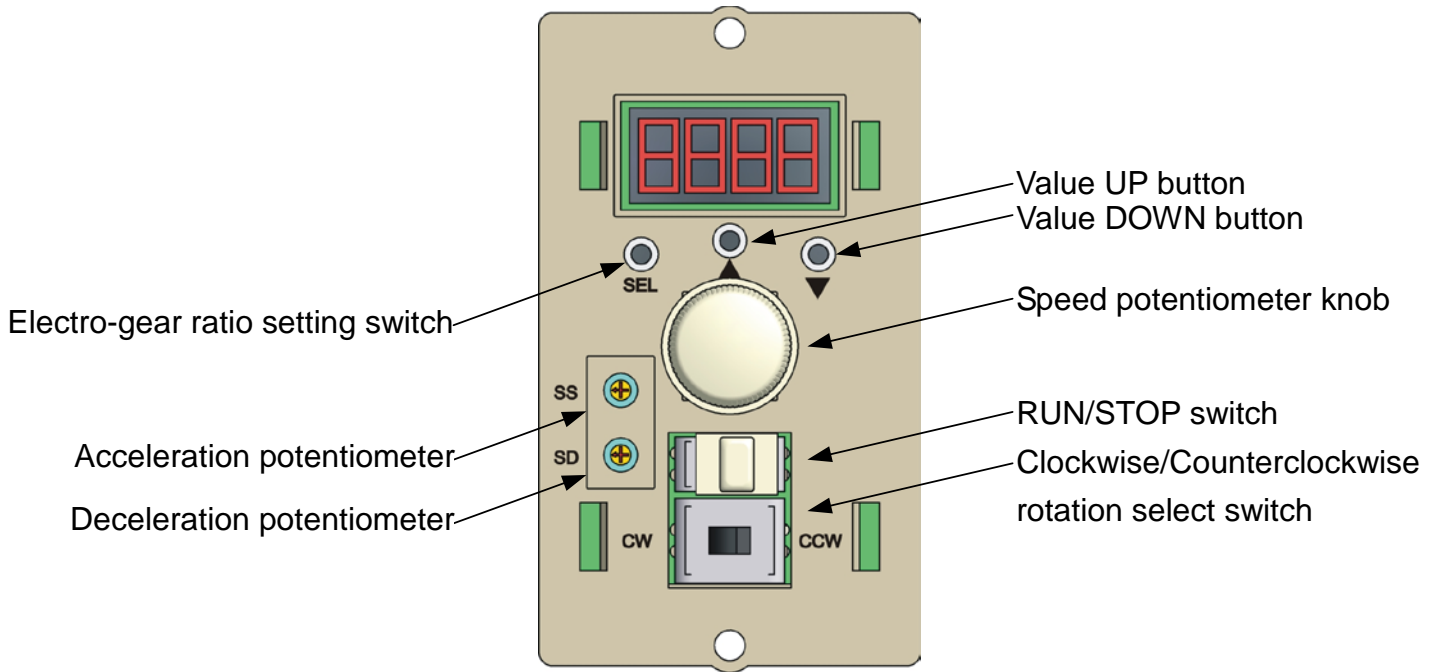

When front panel is removed

*About the electro-gear ratio setting please refer to Page 6

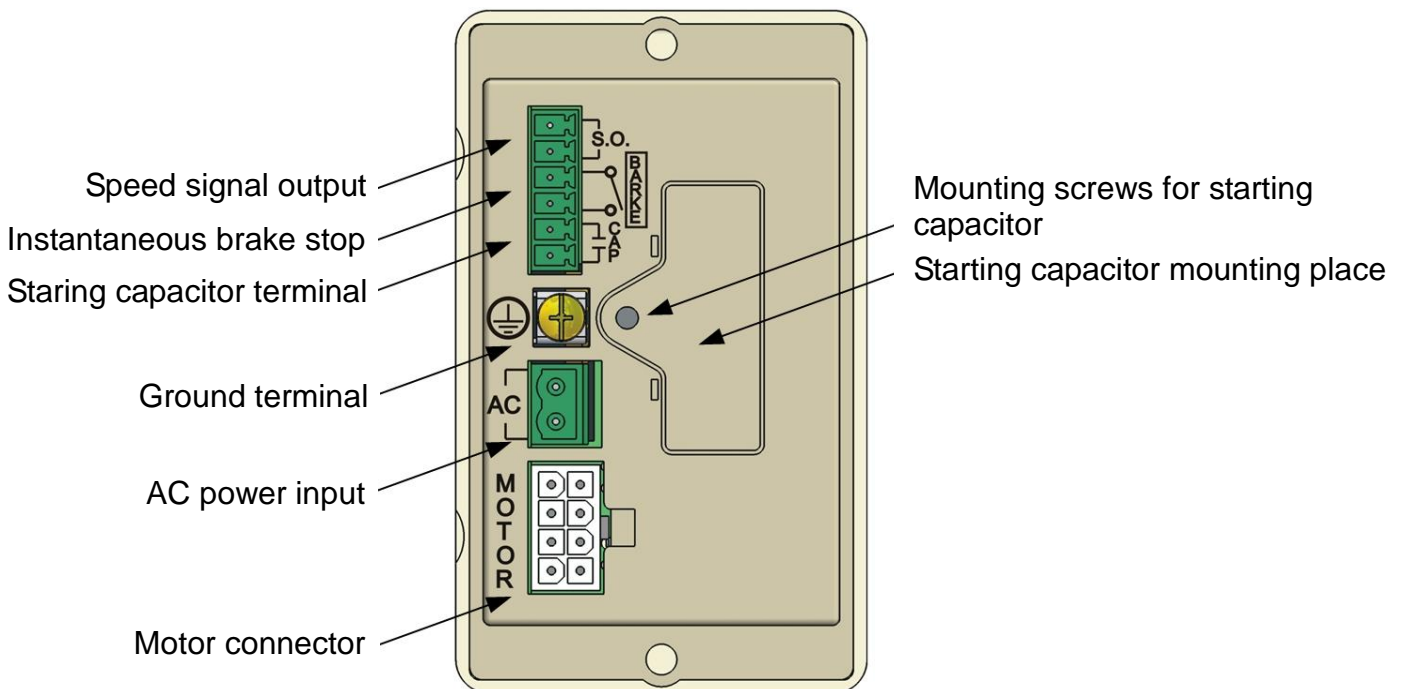

Speed controller rear panel

Item	Name	Functions
Speed display		Motor speed displayed
Electro-gear ratio setting switch	SEL · ▲ · ▼	Setting the ratio or electro-gear ratio of gearhead and indicate the rotation of gearhead output shaft or liner speed of object
Speed potentiometer knob	LOW→HIGH	The knob from LOW to HIGH in the CW direction and speed is become fast Frequency is 50Hz, the speed regulation range is 90~1400r/min Frequency is 60Hz, the speed regulation range is 90~1700r/min
RUN/STOP switch	RUN/STOP	Switching to the RUN side and motor start to operation Switching to the STOP side and the motor stop
Acceleration potentiometer	SS	Acceleration time max 23 seconds(With no load)
Deceleration potentiometer	SD	Deceleration time max 28 seconds(With no load)
Clockwise/Counterclockwise rotation select switch	CW/CCW	When motor operated direction with gearhead direction are different from machinery direction. Selected the direction by this switch
Speed signal output	S.O.	When require monitored the speed which could be monitored by speed indicator via this output
Instantaneous brake stop	BRAKE	These 2 terminals short circuit can make the motor instantaneous stop
Starting capacitor terminal	CAP	Terminal for connected with the starting capacitor
Mounting screws for starting capacitor		Mounted the capacitor attach with motor
Ground terminal		Connected with system ground wire
AC power input	AC	Please input the voltage according to the controller specs
Motor connector	MOTOR	For connecting the motor cable

4. Wiring and operation

4.1 Wiring

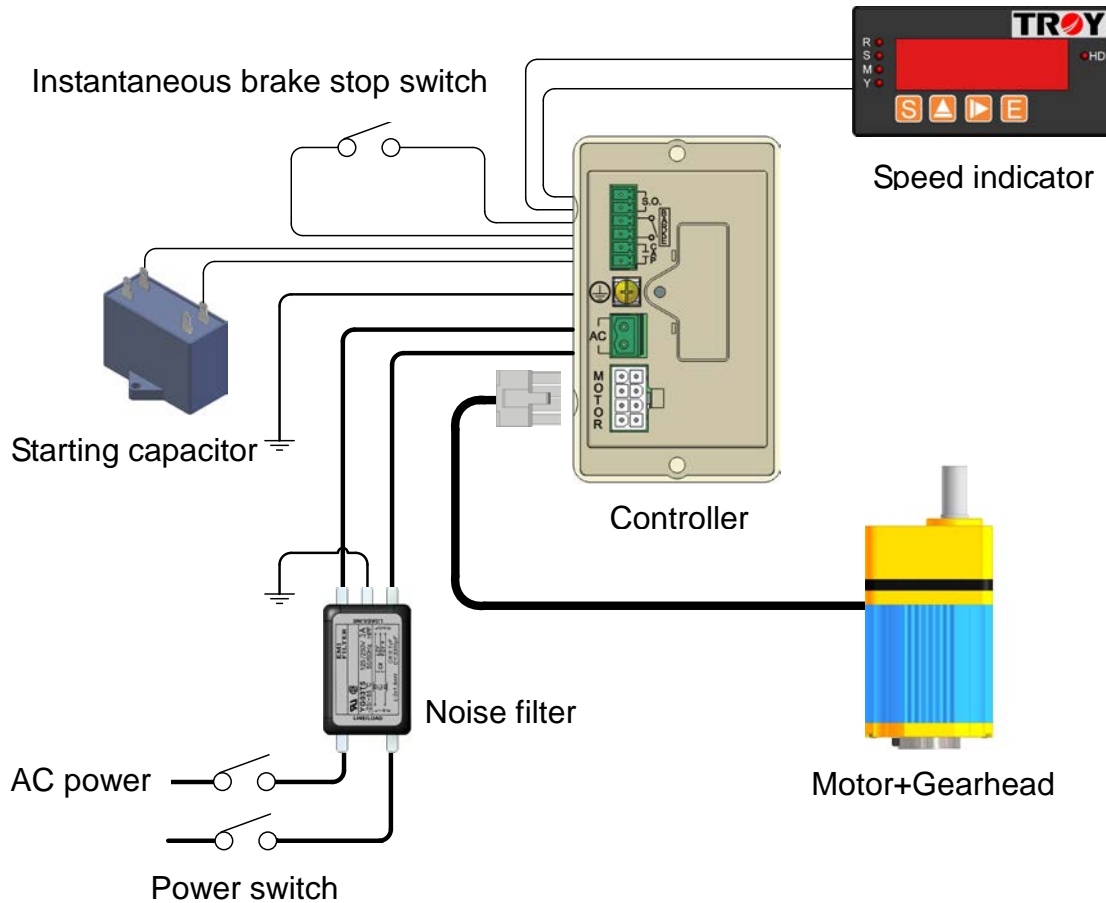

Rated specs of switch	TUD31	TUD32
Power switch	AC125V 10A	AC250 5A
Instantaneous brake stop switch	DC20V 1mA	

※Please use the switch without electrifying contact, do not use the electrifying contact
(Forexample : Transistor output PLC)

4.2 Operation

4.2.1 Operation steps

- (1) Please turn the AC power ON and POWER indicator lit up
- (2) Please turn the RUN/STOP switch to the RUN side
- (3) Turning the speed potentiometer in to the CW direction, the motor speed became fast
- (4) If want to make motor stop, please turn the RUN/STOP switch to the STOP side, then motor will slow and stop by the inertia
- (5) If want to make motor instantaneous stop, please turn the instantaneous brake stop ON and motor stop instantaneously

4.2.2 Electro-gear ratio setting

4.2.2.1 Why have to setting the electro-gear ratio?

(1) When motor attached gearhead and speed indicator will display the gearhead's speed (RPM)

(2) When motor attached the machinery and speed indicator will display the object's liner speed

4.2.2.2 How to set the gear ratio?

(1) Disassembling the controller panel and setting the gear ratio via SEL/▲/▼ buttons

(2) Button's function

*Entering the gear ratio setting mode:

First, press the SEL button and hold it and press the ▼ button until the P shows up then let the SEL/▼ off. After 1 second the indicator indicated the gear ratio value and the first ones at the right side will flickering which means the value could be changed

(Default value: 0001, Indicated the RPM is the motor real speed)

*Exiting the gear ratio setting mode:

First, press the SEL button and hold it and press the ▼ button until the L shows up then let the SEL/▼ off (Gear ratio setting value saving now). After 1 second speed indicator indicated the motor speed (RPM)

*Select the digit number of gear ratio value:

Every time press the SEL button and gear ratio value will flickering by circle

*Adding the gear ratio value:

Pressing the ▲ button and the gear ratio value will increasing (0→9→0→9...)

*Decreasing the gear ratio value:

Pressing the ▼ button and the gear ratio value will decreasing (9→0→9→0...)

*Decimal point and non-decimal setting:

First, press the SEL button and hold it then press the ▲ button. The no decimal will become with the decimal point (First decimal place) and the decimal point will become to non-decimal

(3) For example

Ex1. Setting the gear ratio value (Default) from 0001 to 0030 (The gear ratio 1:30 of gearhead attached with motor)

Step1: First, press the SEL button and hold it then press the ▼ button. After the indicator indicated the P and let the SEL/▼ off. Around 1 second the indicator indicated gear ratio value 0001 and the ones "1" flickered

Step2: Pressing the ▼ button and the number "1" become to "0"

Step3: Pressing the SEL button and the flickering place moved left from ones to tens

Step4: Pressing the ▲ button 3 times and the number "0" become to "3"

Step5: First, press the SEL button and hold it then press the ▼ button. After the indicator indicated the L and let the SEL/▼ off. Around 1 second, the speed indicator will indicate the gearhead's speed (RPM).

Ex2. Setting the gear ratio value from 30 to 12.5(The gear ratio 1:12.5 of gearhead attached with motor)

Step1:First, press the SEL button and hold it then press the ▼ button. After the indicator indicated the P and let the SEL/▼ off. Around 1 second the indicator indicated gear ratio value 0030 and the ones "0" flickered

Step2:Pressing the ▲ button 5 times and the number "0" become to "5"

Step3:Pressing the SEL button and the flickering place moved left from ones to tens

Step4:Pressing the ▼ button and the number "3" become to "2"

Step5:Pressing the SEL button and the flickering place moved left from tens to hundredth

Step6:Pressing the ▲ button and the number "0" become to "1"

Step7:First, press SEL button and hold it then press the ▲ button. After indicated the decimal point and let the SEL button off

Step8:First, press the SEL button and hold it then press the ▼ button. Until the indicator indicated L and let SEL/▼ off. Around 1 second, the speed indicator will indicate the gearhead's speed(RPM)

Ex3. Motor installed on the pulley as below(The diameter of pulley wheel is 8cm) and calculated the Conversion ratio(gear ratio) value of object's liner speed(M/min)

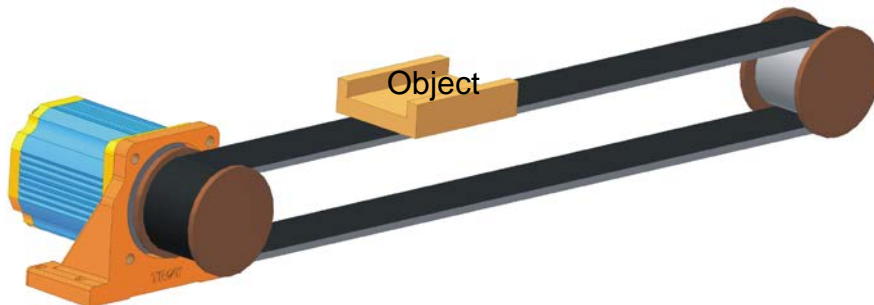

$$\text{Formula: Conversion ratio} = \frac{1}{\text{Diameter(M)} \times \pi}$$

Explanation:

Motor operated per rotation and the distance which object moved: $(8 \div 100) \times \pi \doteq 1/4(\text{M})$

When motor speed is 1600RPM and object's liner speed is: $1600 \times 1/4 = 400(\text{M/min})$

In this sample the conversion ratio(gear ratio) value is 4

If gear ratio value set "0001" and the speed indicator indicated motor speed: 1600(RPM)

If gear ratio value set "0004" and the speed indicator indicated object's liner speed: 400(M/min)

4.2.2.3 Gear ratio setting and speed indication cautions

(1) Gear ratio value < "0003" and with no decimal, the indicator indicated the units digit is 0

(2) Gear ratio value > or = "0003" and with no decimal, the indicator indicated the units digit is the actual test value

- (3) Gear ratio value is the decimal mode ex: "003.6", the indicator indicated the units digit is the actual test value
- (4) If the gear ratio value < "0003" and indicator has to indicated the units digit. Please setting the gear ratio value as the decimal mode ex: "001.0" or "002.0" and the indicator indicated the units digit is the actual test value

4.2.3 Operation cautions

- (1) Do not control the motor run/stop by power switch, when power turned on the motor operated at the same time and generated surge current which will cause the controller damaged
- (2) RUN/STOP switch is not the power switch of the controller. If want to make motor stopping for long time, please turn the controller power OFF
- (3) Restarting the instantaneous stop please restarted it after more than 0.5seconds. During the continuous run/stop, make sure the using frequency not over the 4 seconds(Run and stop each over 2 seconds). The using frequency over high will cause to the controller damage

4.2.4 CW/CCW operation cautions

- (1) When switch the CW/CCW direction, please turn the RUN/STOP switch to the STOP side and turn off the power
- (2) Do not switching the CW/CCW during motor operation and controller will damage easily

4.2.5 Motor connection

Extension cable 1 m provided with the controller, if the length is not long enough and want to extend the length. Please used the extension cable which we provided(Sold separately). The max length can extended to 5 m and do not use too many extension cables to extended length which will lead fault action. When connection turn off the power first to avoid the un-proper contact caused the controller damage

4.2.6 Extension cable specs

Model	Length(m)
CU-010	1
CU-020	2
CU-030	3
CU-050	5

5. Installing

5.1 Starting capacitor installation

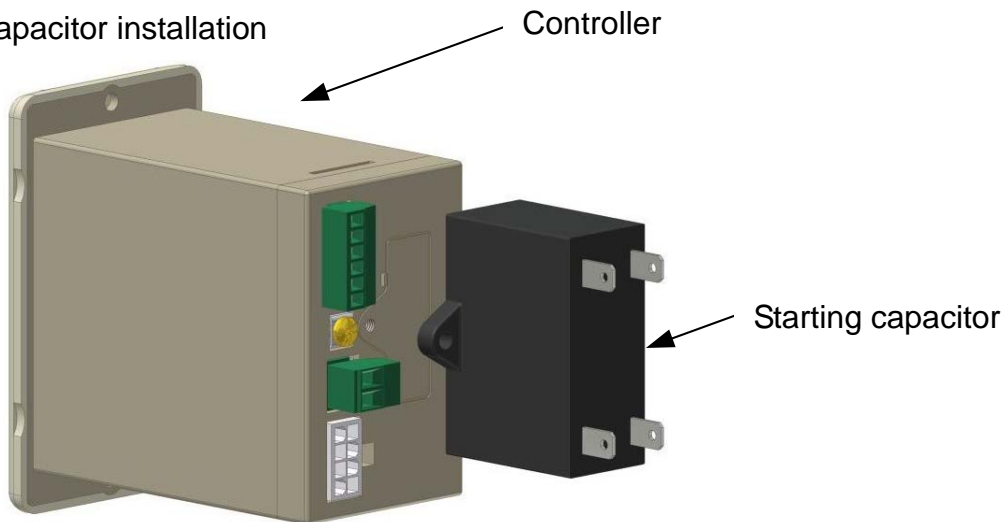

Step 1. Taking out the capacitor from the package

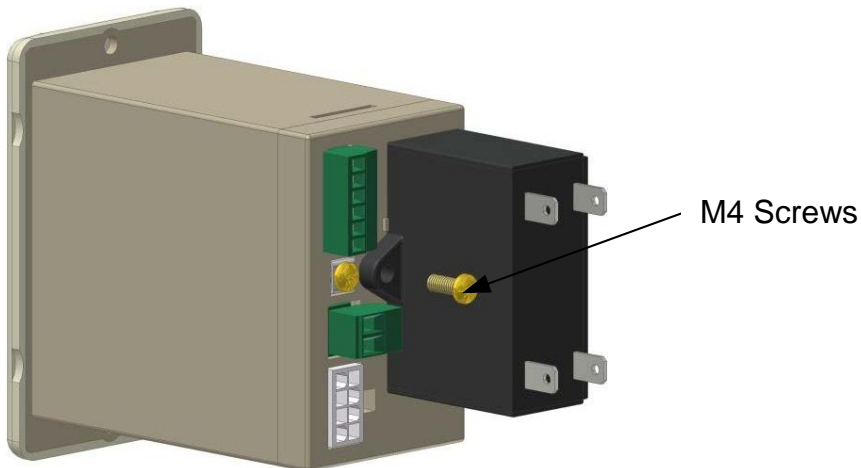

Step 2. Mounting the starting capacitor on the controller by M4 screws

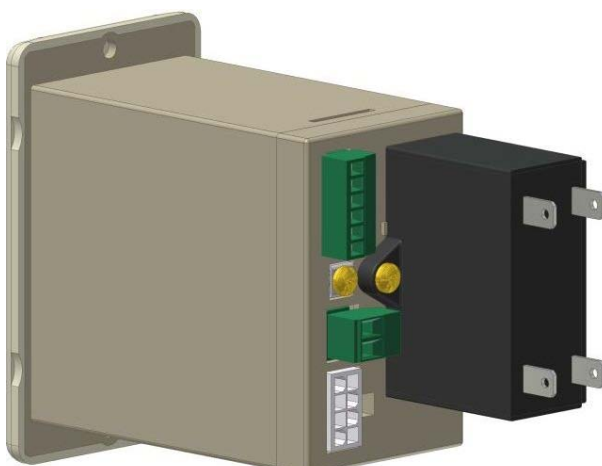

Step 3. Finish

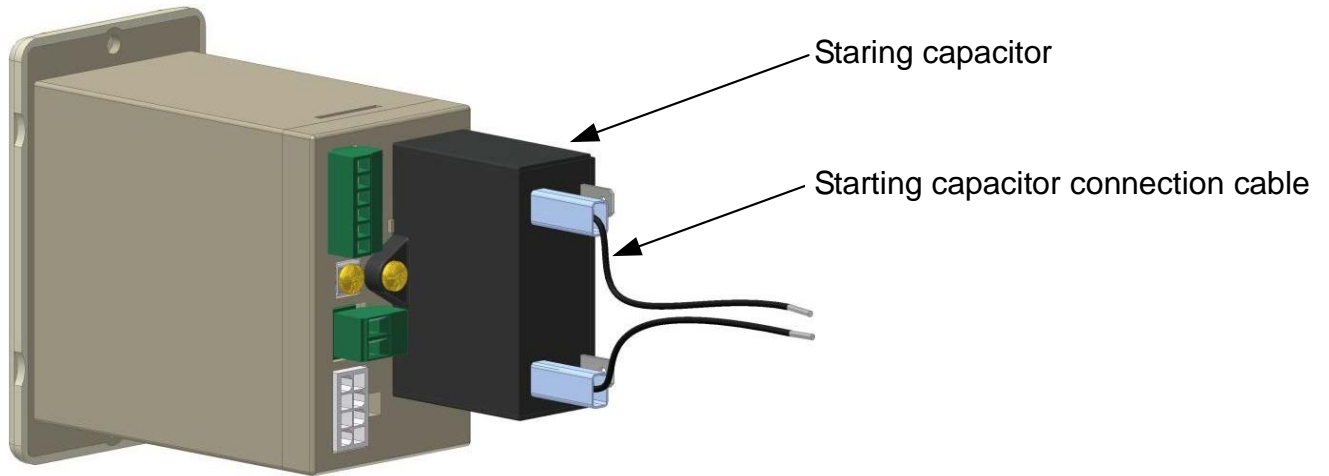

Step 4. Taking out the starting capacitor connection cable and mounting on the capacitor

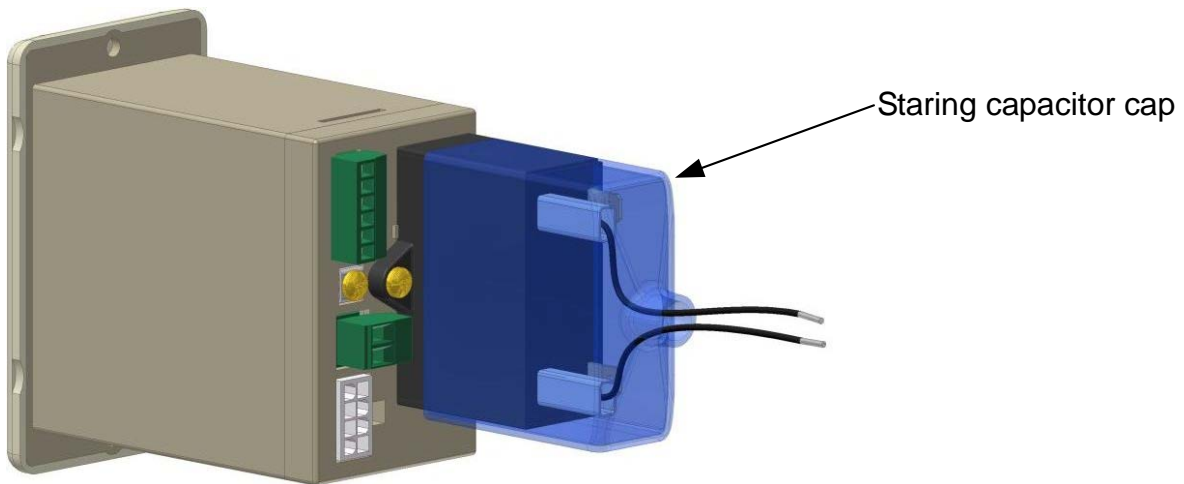

Step 5. Put the starting capacitor into the starting capacitor cap

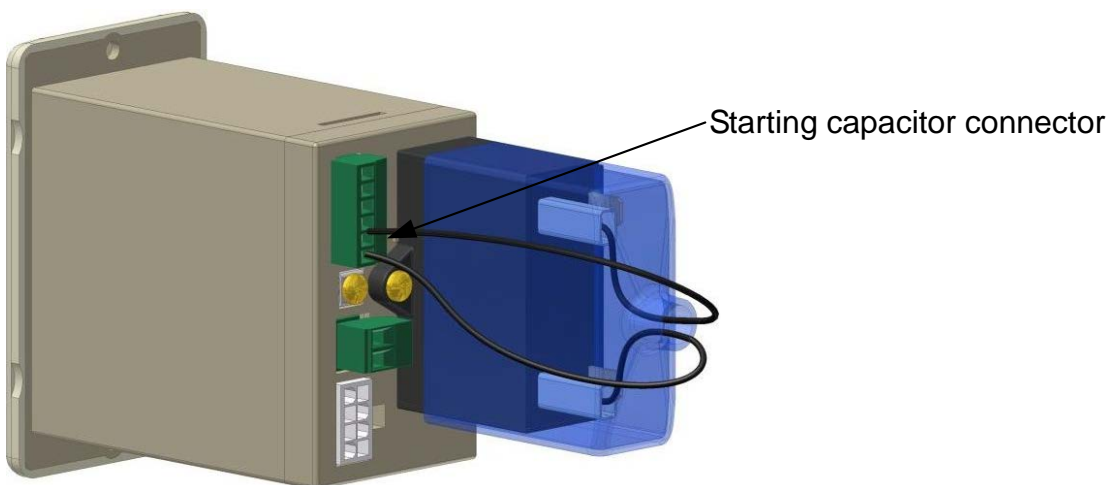

Step 6. Connecting the lead from the starting capacitor to the starting capacitor of controller's connector then finish

5.2 Controller installation

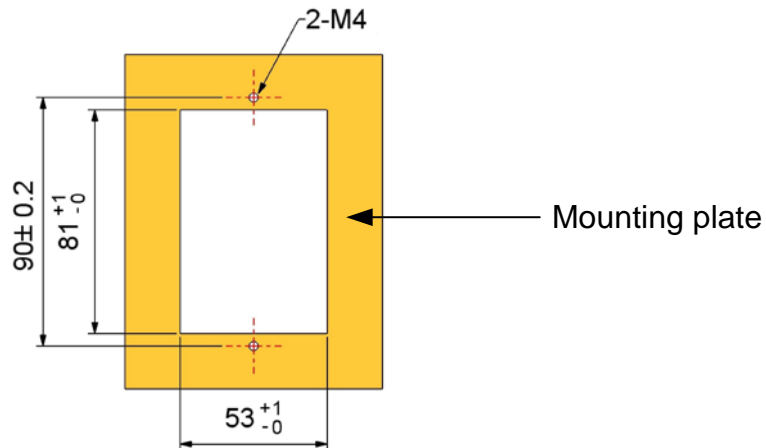

Step 1. Please follow the diagram and drilling

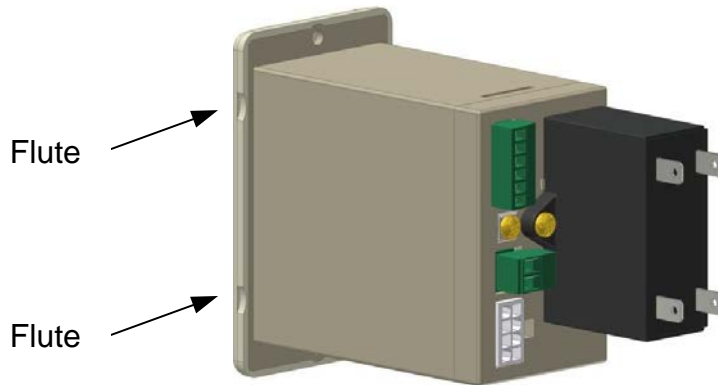

Step 2. Pulling the flute out of the controller side and take out the panel

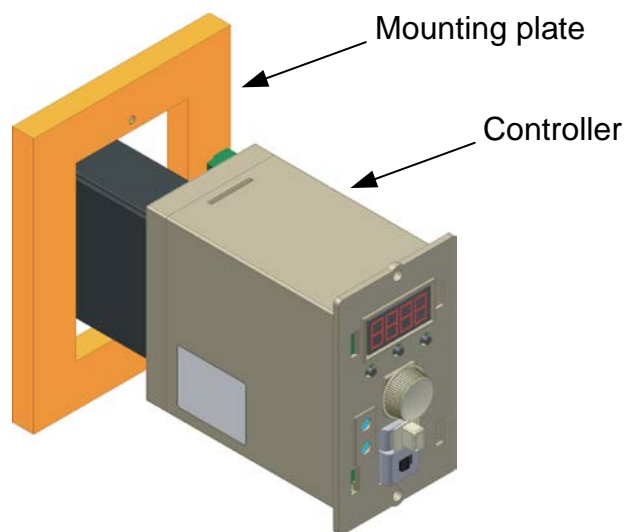

Step 3. Put the controller into the mounting plate which drilled

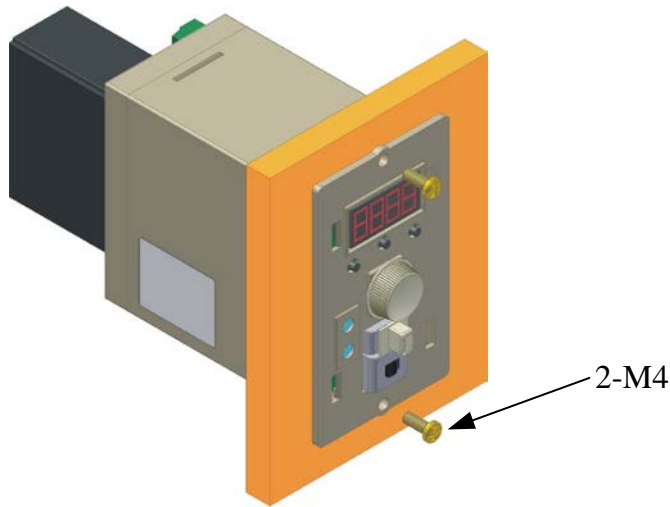

Step 4.Mounting the controller by M4 screws(2 pcs)

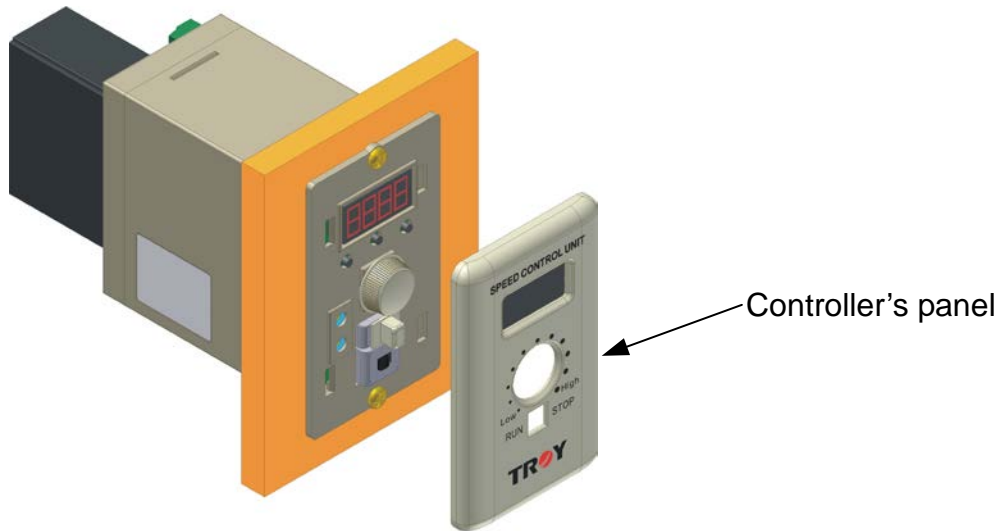

Step 5.Put the panel on the controller



Step 6.Finish

6.Dimension

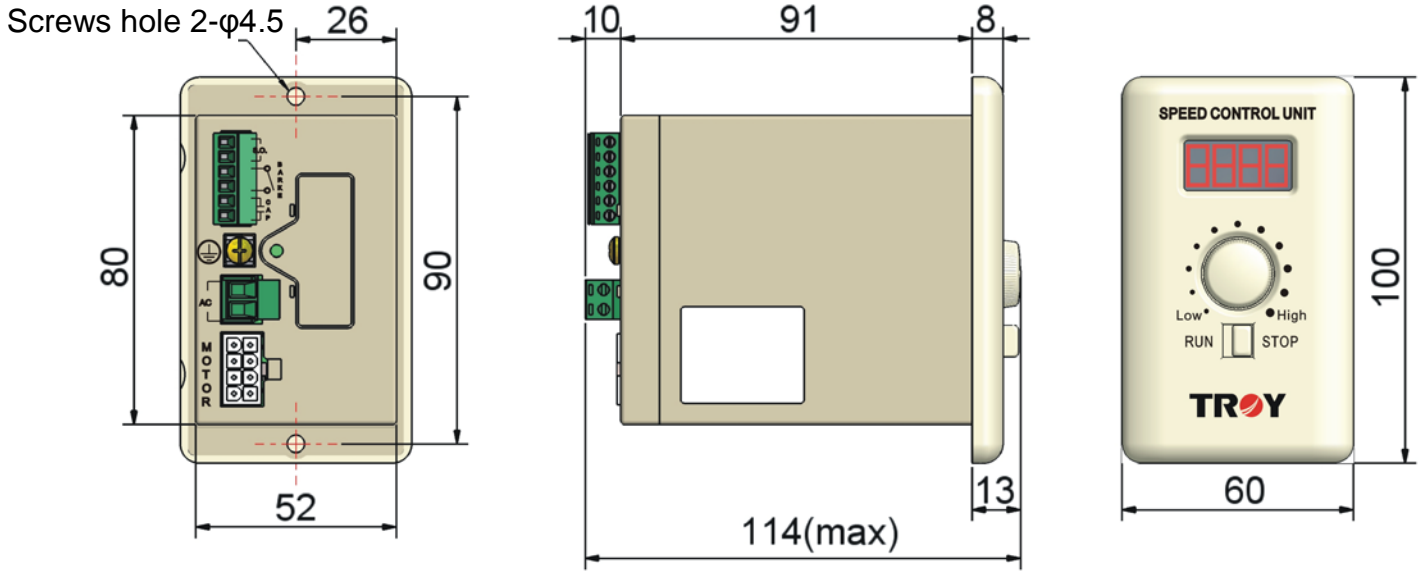

*For environment protection, paper saving and resources preservation, please download the user's manual directly from TROY website : [http:// www.troy.com.tw](http://www.troy.com.tw)

- ◆Our constant aim Demand for professionalism
- ◆Our belief Commitment to every detail
- ◆Our innovation Introduction of cutting-edge equipments
- ◆Our pride Pursuit of superior products

We are confident that each TROY products bears tests

For we are highly motivated !

TROY TROY ENTERPRISE CO., LTD

Professional manufacturer

Website : www.troy.com.tw

E-mail: sales@troy.com.tw

TEL : +886-2-2299-9839

