

# TB50 BRAKE PACK

Induction Motor--Bi-directional Operation, Electronic /Electromagnetic Brake Control Functions

## User's Manual



Bi-directional operation, electronic/electromagnetic brake control functions integrated into one unit

Overheat protection equipment for detecting ALARM output

None contact controlling

※ Use smart phone to scan it to read online



# 1











## Specs

Controller model	TB50	
AC Power input (V)	① Single phase 100-115V ② Single phase 200-230V ✕	
DC Power input (V)	DC 23~26V	
Power frequency (Hz)	50	60
Drive current (A)	3	
Drive power	Max. 90W	
Function	<ul style="list-style-type: none"> <li>● Instantaneous stop</li> <li>● Bi-directional operation</li> <li>● Electromagnetic brake release</li> <li>● Thermal protector open detection (ALARM Output)</li> </ul>	
Ambient temperature	0 ~ +40°C	
Ambient humidity	MAX. 85%	
Dimension (mm)	104(L) X 65(W) X 44(H)	
Weight (G)	160	

✕ According to the Motor input power specification, please select the input power

## WARNING

✕ May cause dead or serious injury etc.

Take protective device of over current, instant stop, over temperature, ground fault interrupter.	 Prevent fire, injury, electric shock
Do not use product near explosive, water, corrosive gas, or combustible material.	 It may cause fire
Do not forcibly put stress, or lead a heavy article on or stuff foreign matter into it.	 It may cause electric shock, trouble, and damage
Avoid damage caused by earthquake, fire, artificial accident, please set and fix it for confirmation.	 Prevent electric shock, injury, fire, trouble and damage
Install an external emergency stop circuit to turn the power off in the instant halt of operation.	 Prevent electric shock, injury, fire, trouble and damage
Connect the Brake and Motor to ground.	 Prevent electric shock
Neither reach nor touch the Brake terminals while power is on.	 It may cause electric shock
Execute safety examination after earthquake	 Prevent fire, injury, electric shock
Have a professional expert set the wiring construction accurately.	 Prevent electric shock, injury, fire, and trouble
Do not work for moving, wiring or inspection with the power on	 Prevent electric shock, injury, fire, and trouble
Do not touch the internal parts of the Brake.	 It may cause electric shock , scald

Do not stand/sit on product or put heavy article on it.



It may cause electric shock, trouble, damage

Ensure that wiring has been correctly done.



Prevent injury trouble, damage

※Please dealing according to industry littering as discarding the product.

## ATTENTION

※May cause injury or product damage.

When conducting trial operation, make Motor fixed. Confirm motion before composing machine system.



Prevent injury

When temperature of Brake or Motor is rising, please do not touch it.



It may cause scald.

Do not reform, assemble or repair the Brake.



It may cause electric shock, injury, fire.

Move the product with a great care so as to prevent from the danger such as tumble or turnover.



It may cause injury, damage.

When power recovers after interruption, don't approach devices since it may restart operation suddenly.



It may cause injury.

Please follow the appointed voltage.



Prevent injury, fire, electric shock

Do not cut-in or off the power frequently.



It may cause trouble.

Do not use damaged Brake or Motor.



It may cause injury, fire.

Do not put obstacle around Brake and Motor or it'll be airless.



It may cause scald, fire.

Please have the cause troubleshooting as tripping, and restart after safety confirming.



Prevent injury

Have an expert execute maintenance and inspection.



Prevent injury and electric shock

Neither block nor stuff the aspiration/exhaust vent with foreign particle.



It may cause electric shock, trouble, fire.

Use Brake and Motor in designed combination.



Prevent fire

Do not put a heavy impact on shaft of Motor and Brake



It may cause trouble.

Please turn power off as stop using for a long period.



It may cause injury from wrong operating.

Mount the product on an incombustible material such as metal.



Prevent fire

Do not set magnetic contactor in main power during Motor rotating or stopping.



It may cause trouble

Do not drive Motor axis from external.



It may cause fire, trouble, electric shock.

# 2

## Dimension

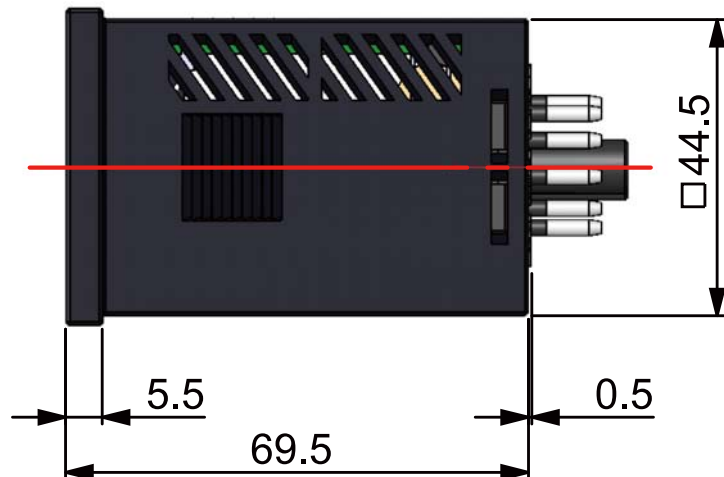
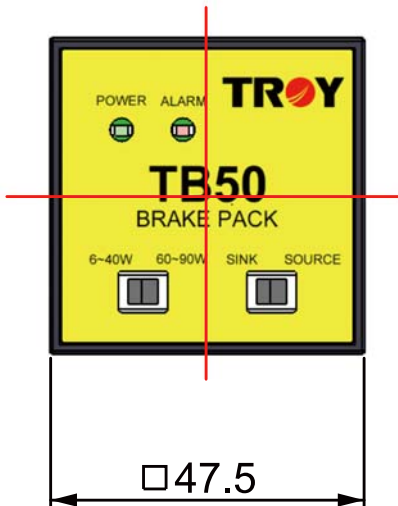
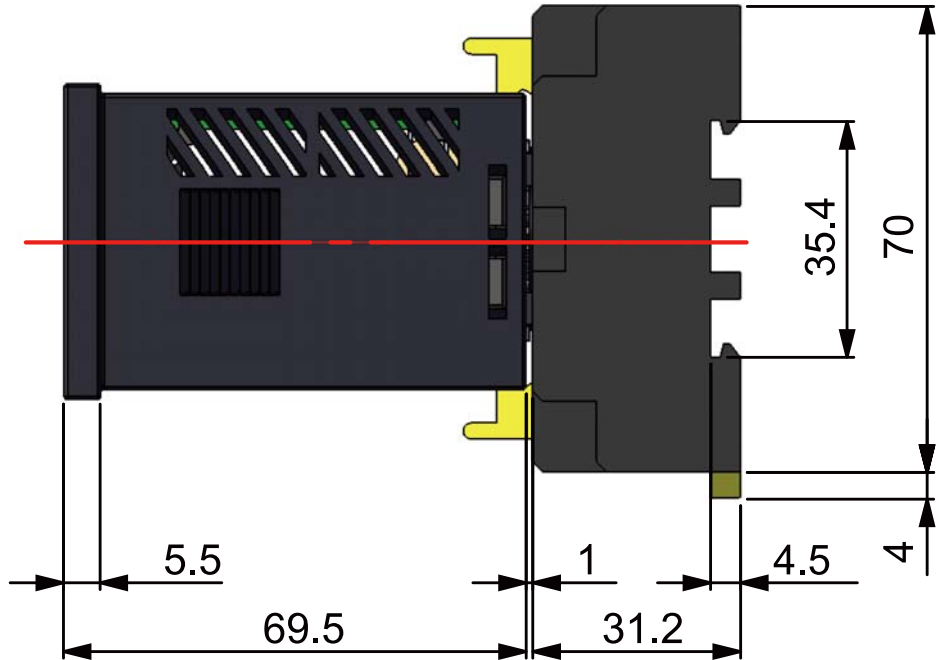
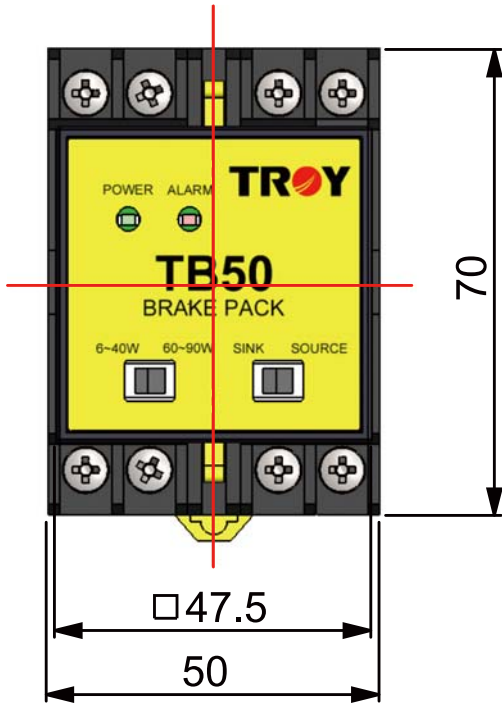

# 3

## Timing Chart

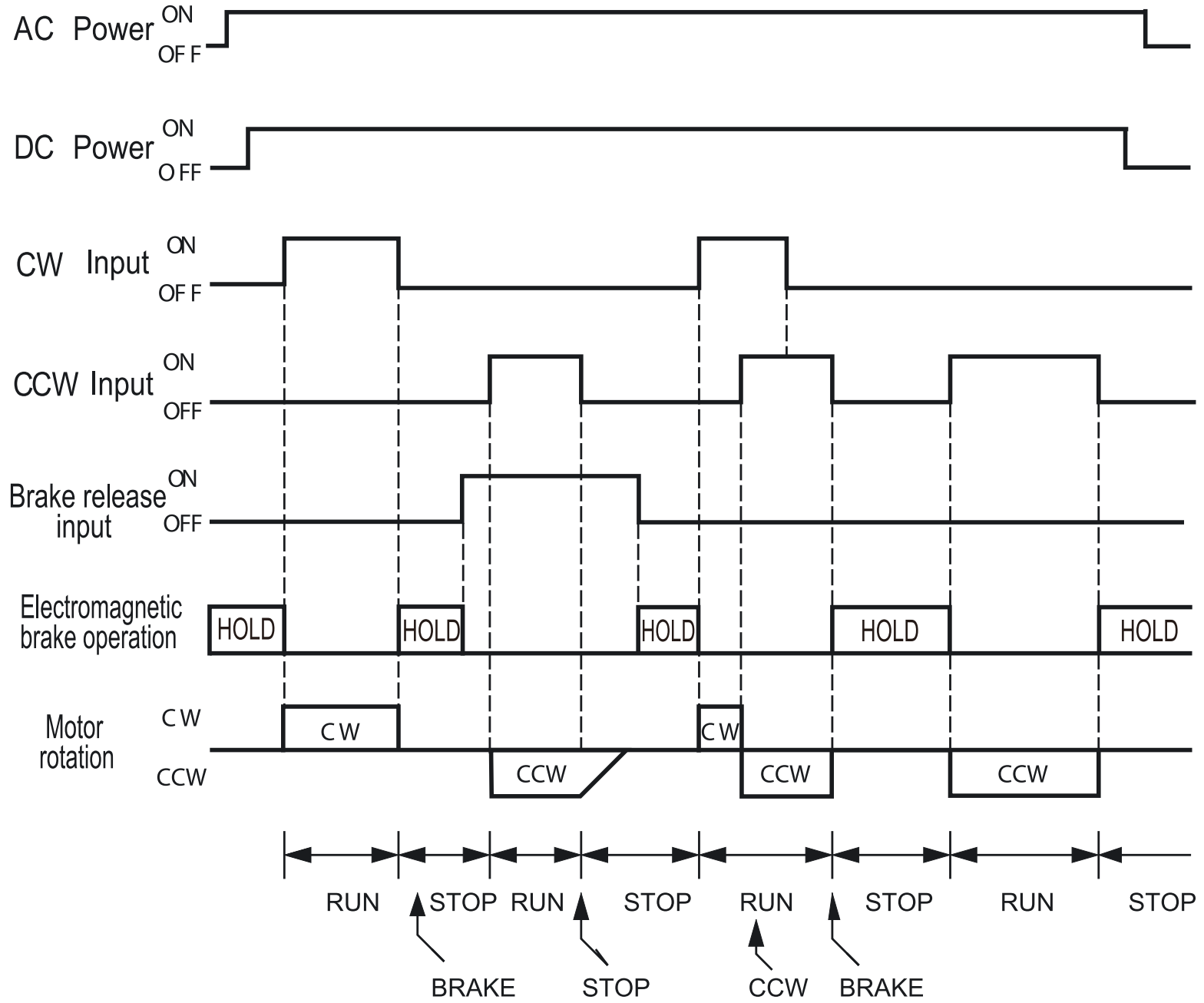

# 4

## Names and Functions

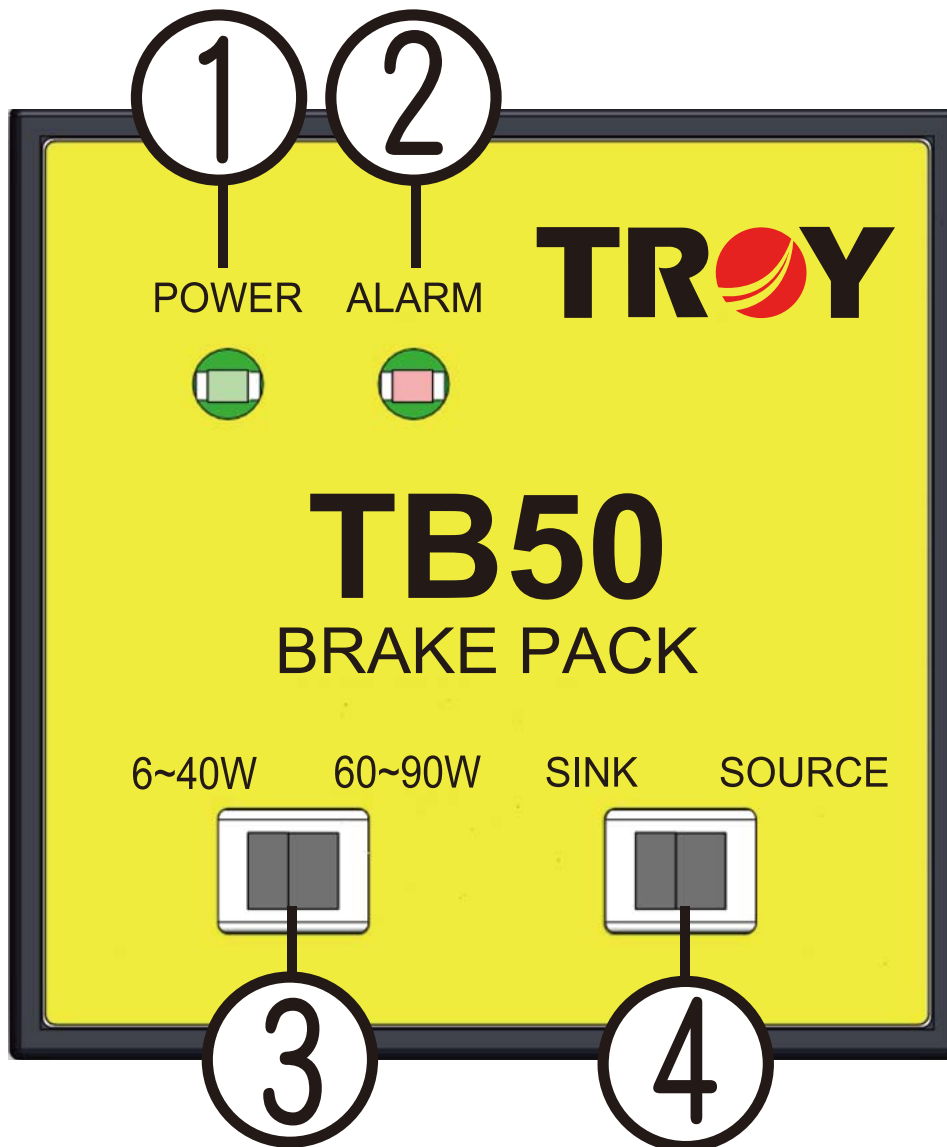

NO.	Name	Factory setting	Function
1	POWER indicator (GREEN)		Lights when 24VDC is supplied.
2	ALARM indicator (RED)		Lights when the ALARM is activated. (The ALARM output is "OFF" )
3	Motor output wattage select switch	60~90W	Set to the motor output.
4	SINK/SOURCE select switch	SINK	Used to switch between Sink/Source for the control signal input/output.

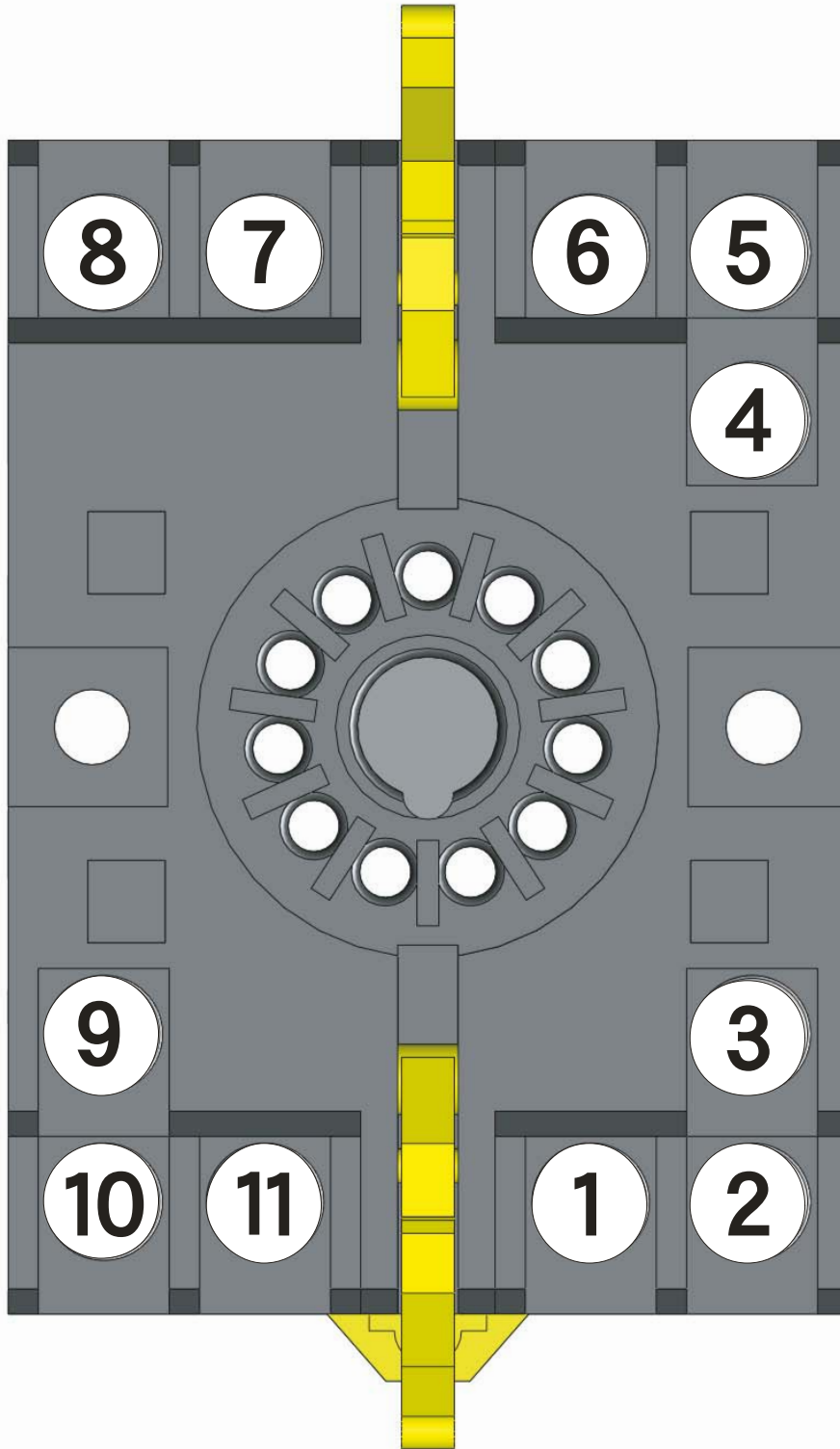

# 5

## Terminal Wiring Instruction

Terminal No.	Signal name	Description
1	Motor / Capacitor	Connect to the motor / capacitor
2	AC POWER input (L)	or Single phase 100-115V Single phase 200-230V
3	NC	Not used. Leave the terminals unconnected
4	Brake relieve input	Not an instantaneous stop but coast to a stop
	ALARM-RESET input	Reset ALARM output
5	CCW rotation input	Motor rotates in the CCW direction during "ON"
6	DC	+DC24V Input
7	GND	GND
8	CW rotation input	Motor rotates in the CW direction during "ON"
9	ALARM output	Turns off when the motor's thermal protector is open
10	Electromagnetic Brake	Connect to the electromagnetic brake
11	Motor / Capacitor	Connect to the motor / capacitor

# 6

## Connection Diagram

➔ Induction Motor - **SINK Mode** Wiring diagram

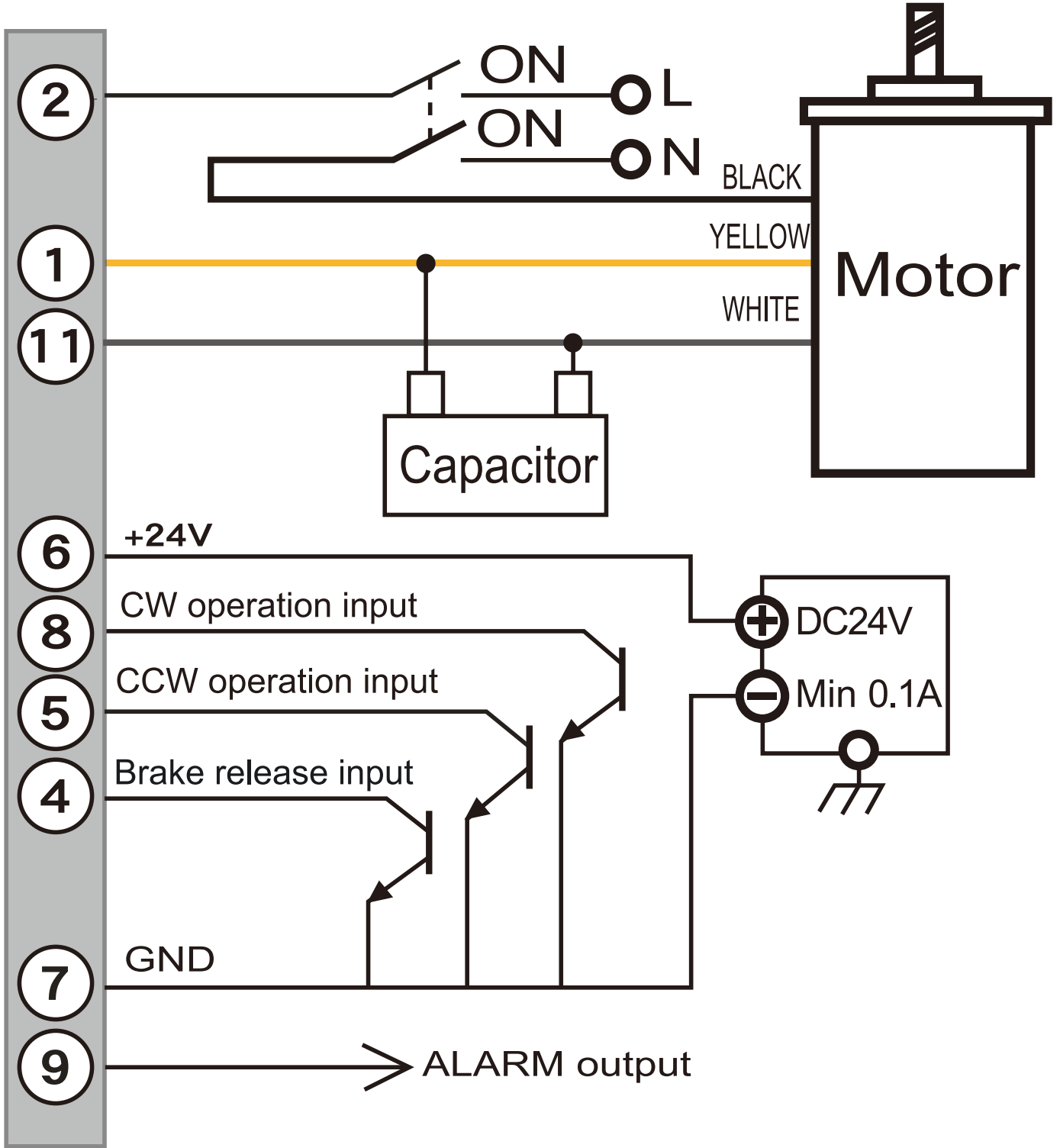

# Electromagnetic Brake Motor - **SINK Mode** Wiring diagram

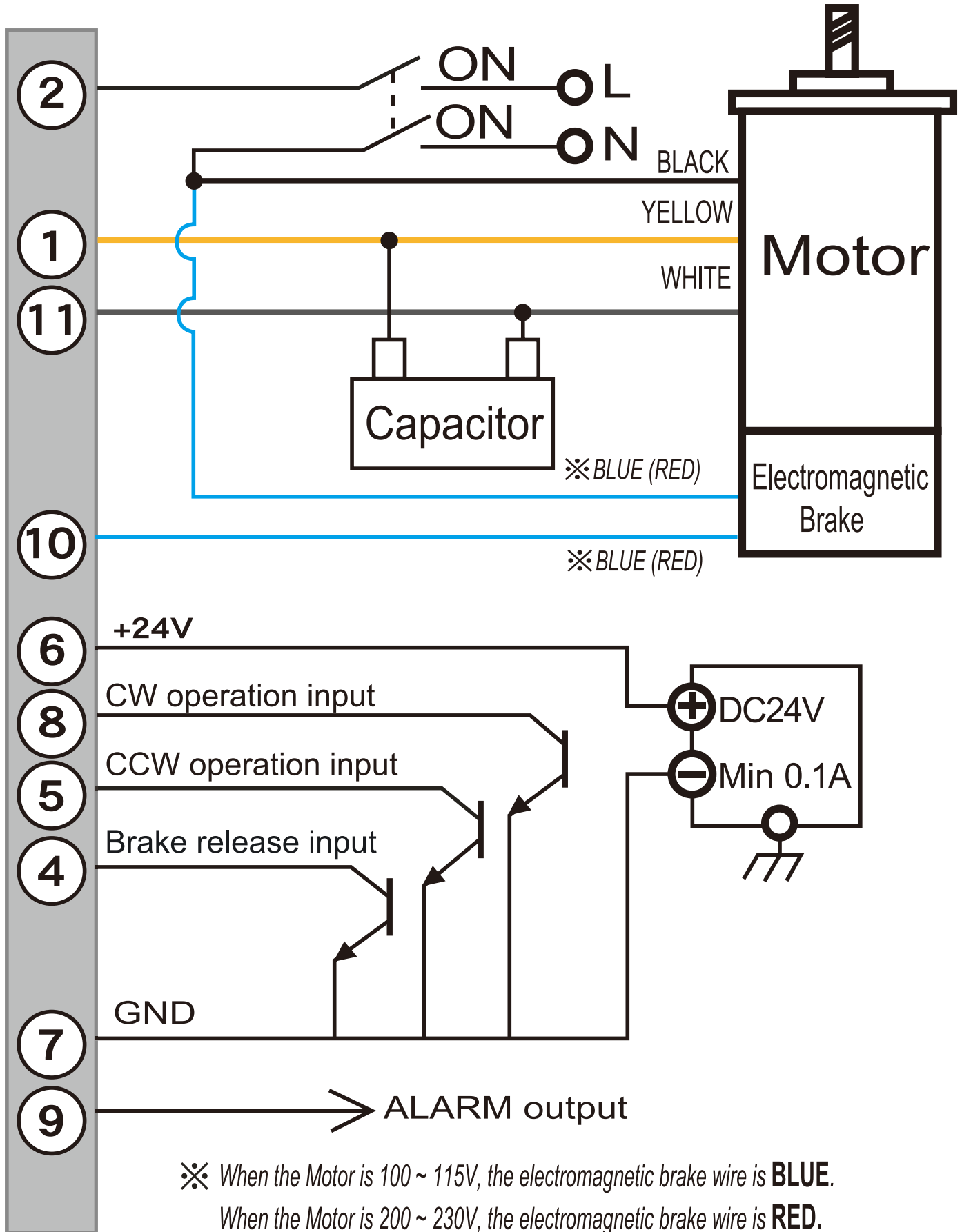

# ➔ Induction Motor - SOURCE Mode Wiring diagram

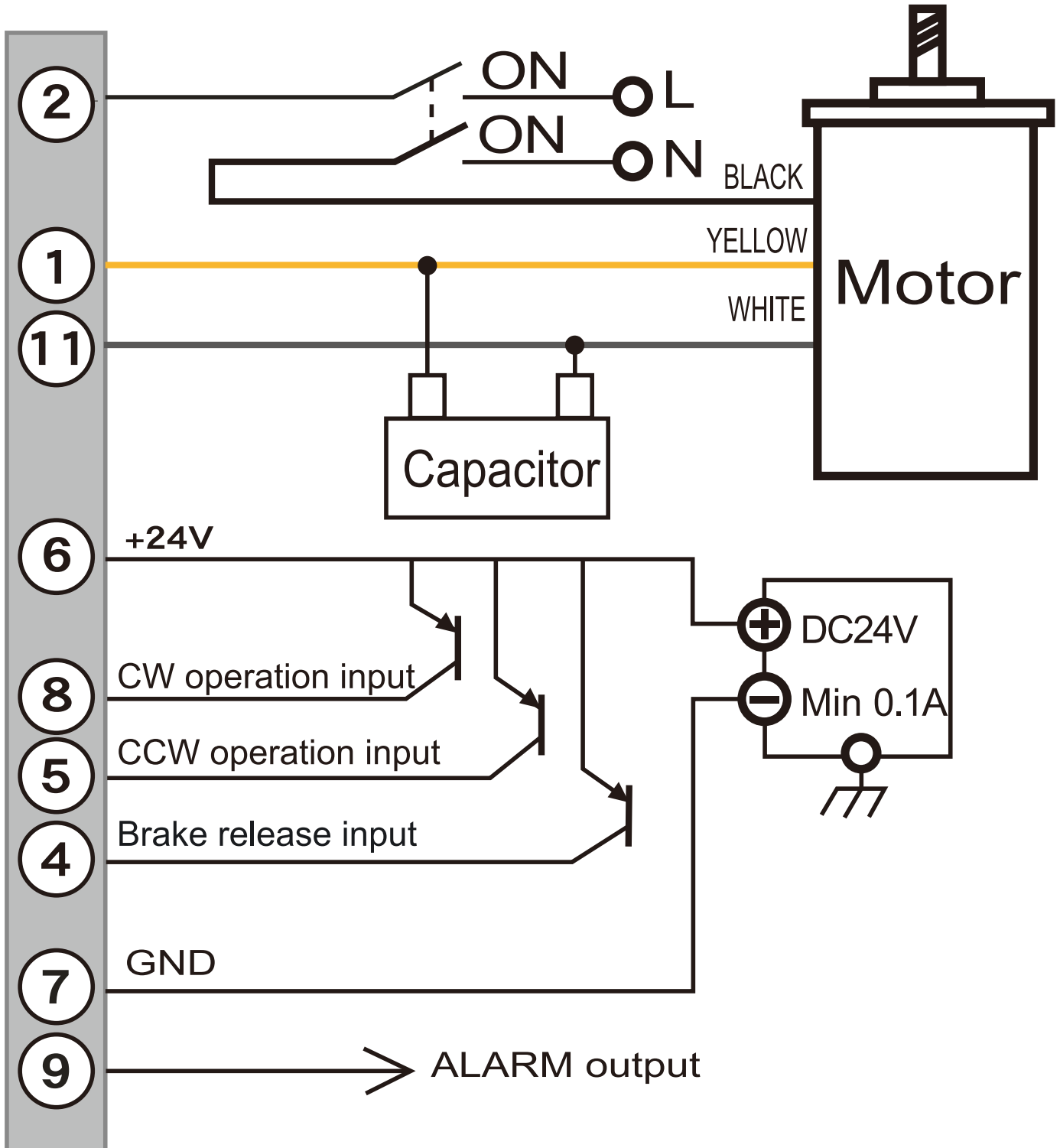

➔ Electromagnetic Brake Motor - **SOURCE Mode** Wiring diagram

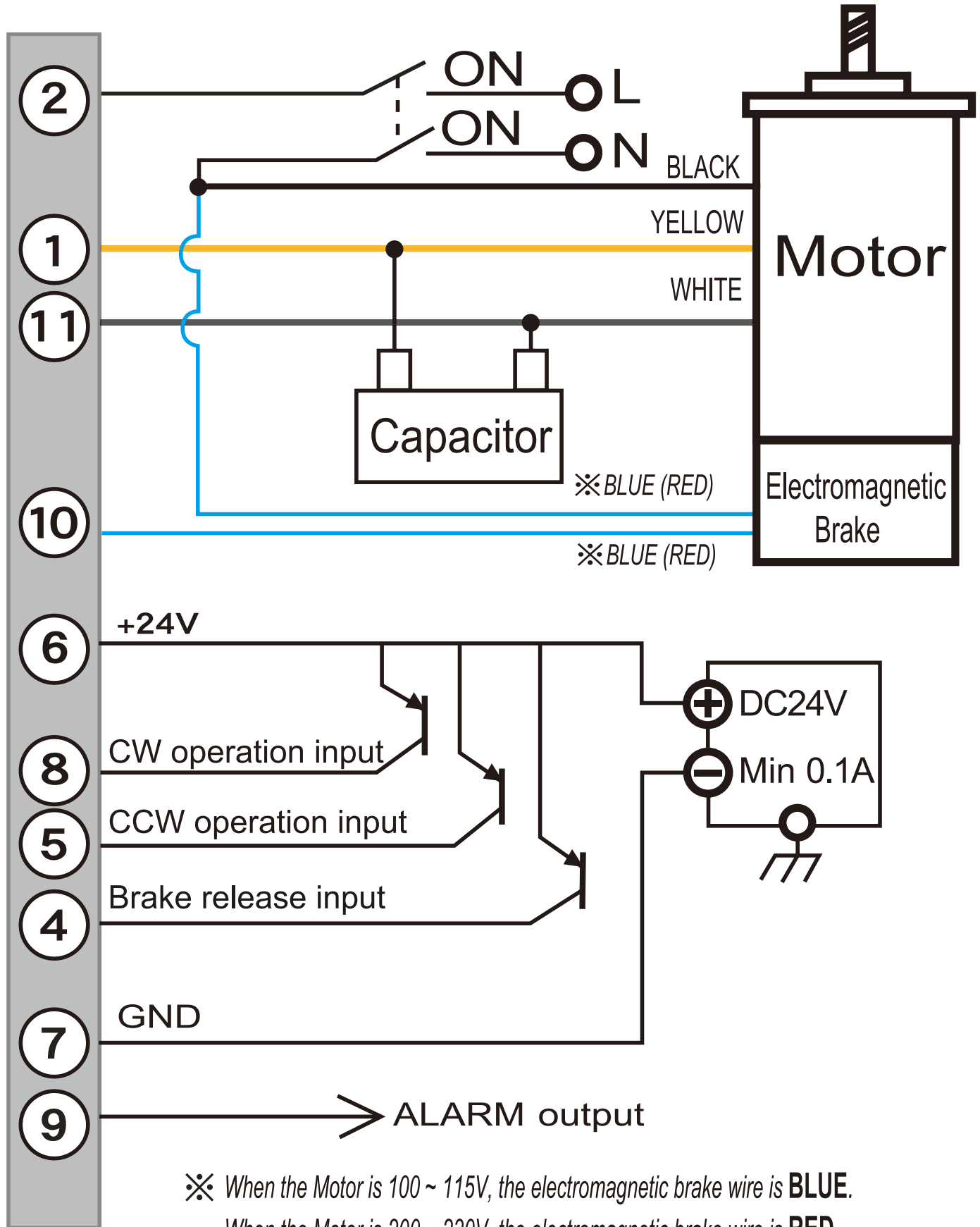

※ When the Motor is 100 ~ 115V, the electromagnetic brake wire is **BLUE**.  
 When the Motor is 200 ~ 230V, the electromagnetic brake wire is **RED**.

# 7

## Input / Output Circuit

### Logic-SINK Mode Setting

#### 1 SINK(NPN)INPUT

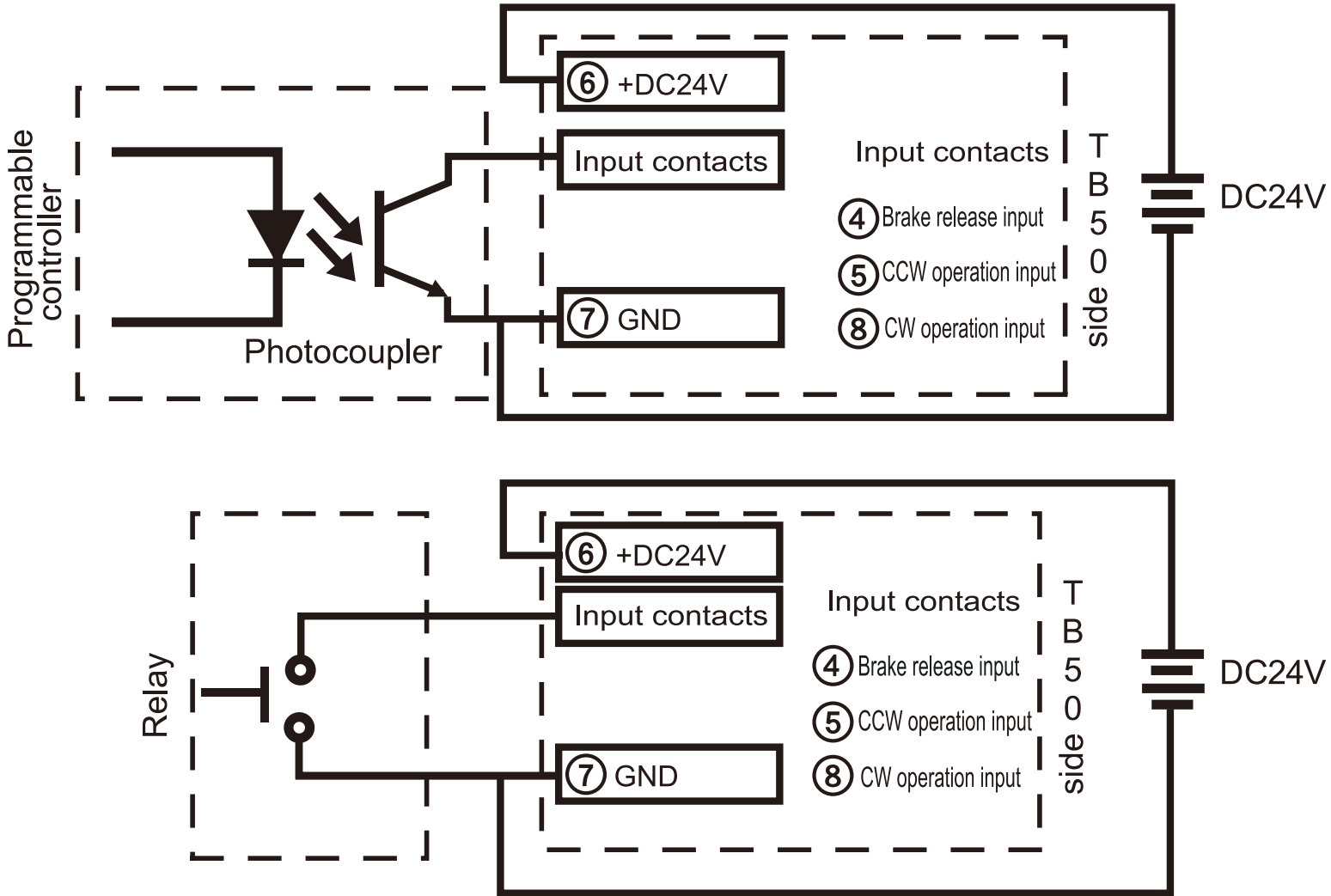

#### 2 SINK(NPN)OUTPUT

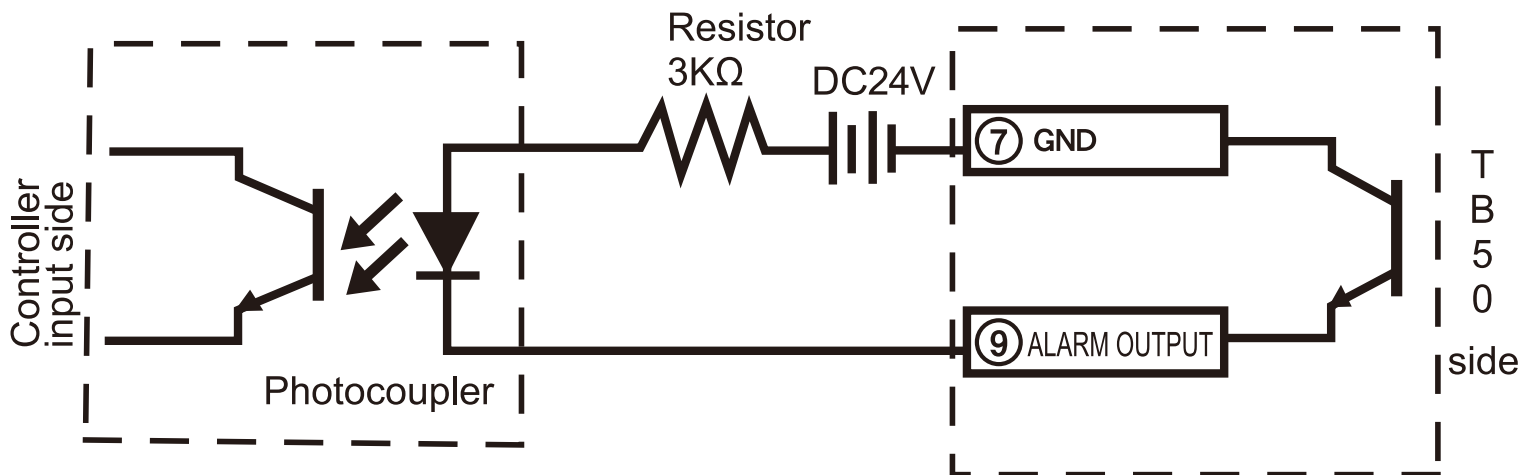

# Logic-SOURCE Mode Setting

## 1 SOURCE (PNP) INPUT

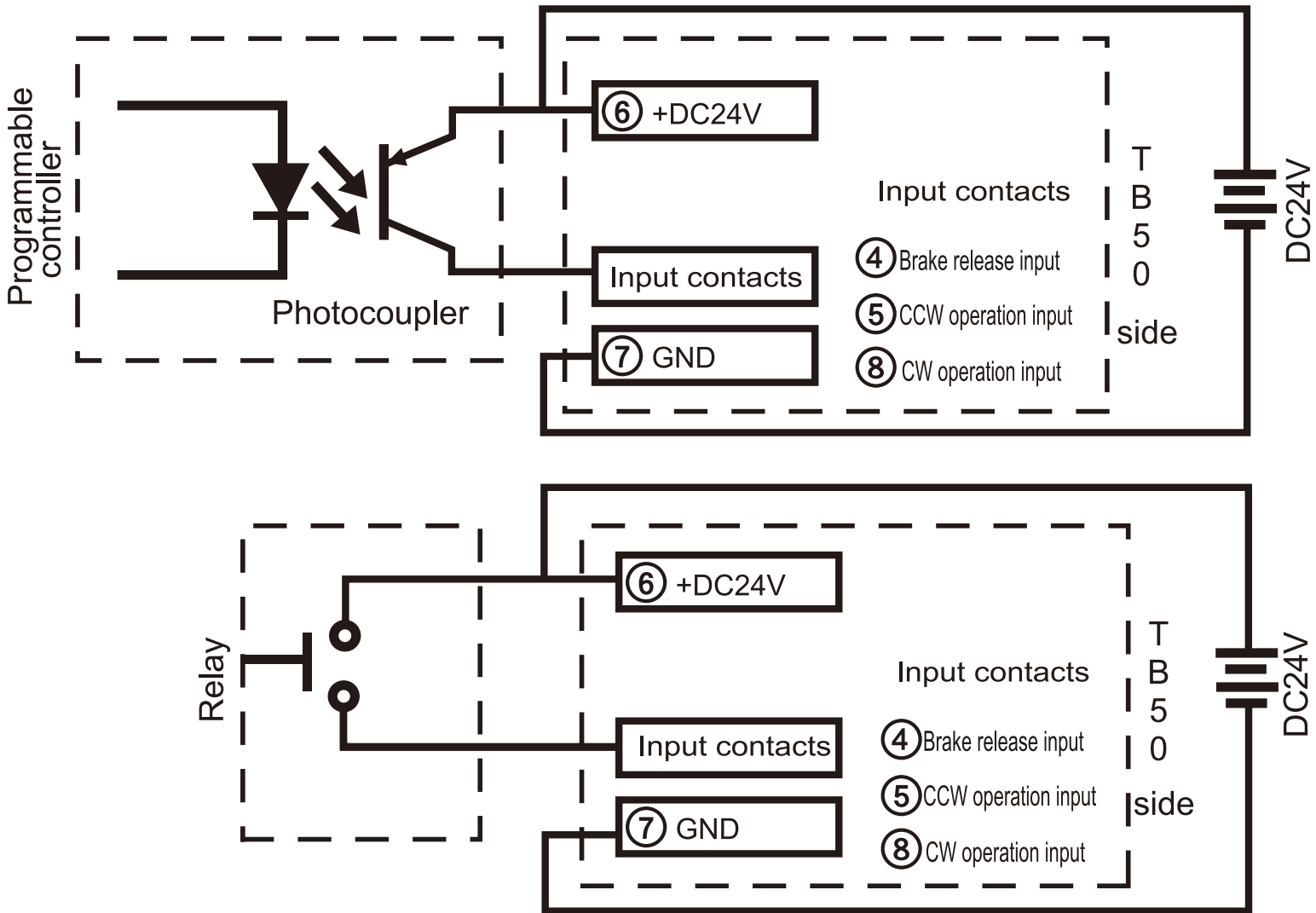

## 2 SOURCE (PNP) OUTPUT

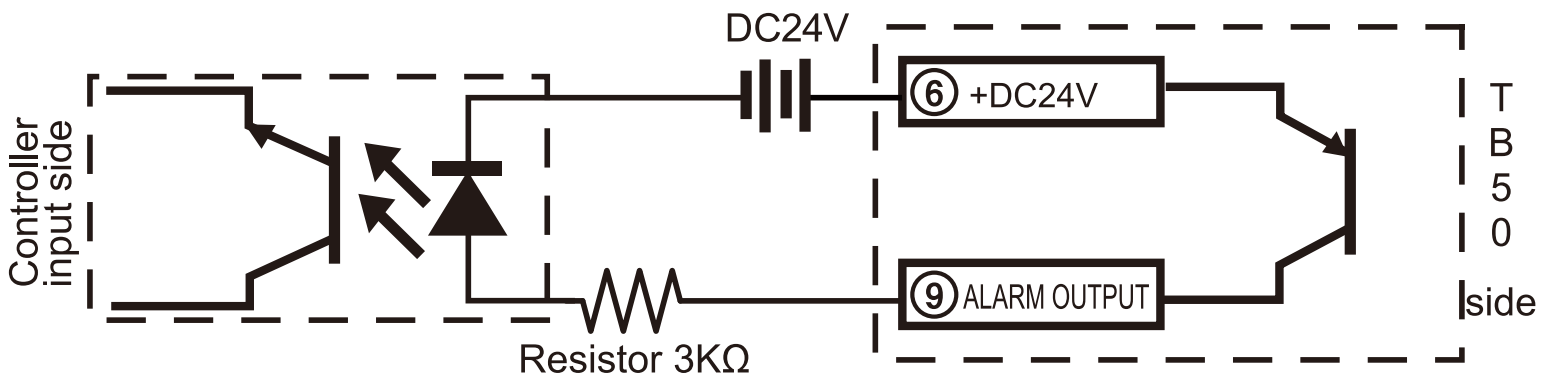

## ALARM Output (thermal protector open detection)

1	When the motor's built-in thermal protector is activated(OPEN)
2	When there is improper connection/disconnection of the power supply cable and motor cable.
3	Before supplying the AC power,the CW rotatiin input \ CCW rotatiin input \ brake relieve input , these input signals are turned "ON".

※ When the ALARM function is activated and ALARM output is "OFF" Also the ALARM indicator lamp (RED) lights up, and the power to the motor is cut off. With electromagnetic brake motors, the brake is activated in order to hold the load in position.

## ALARM-RESET

1	When relieving the ALARM status, please remove the ALARM reasons and make sure it is safe then operate it again. Please set the input signals for "OFF" and then set the brake release input signal for "ON" for at least 0.5 seconds. Wait at least 0.5 seconds after turning the ALARM-RESET input "OFF" before restarting operation.
2	It is also possible to deactivate the ALARM by turning off the power supply and turning it on again. Turn off the DC or AC power supply, and turn all input signals "OFF" before turning it on again.

# 9. Trouble Shooting

If the Motor running condition can not operate normally, please refer to the instruction below to deal with.

Situation		Solution
Motor -: No rotation Too low speed	ALARM lamp lights up	<p>Please remove the reasons of the ALARM output reasons.</p> <p>The action of the Motor overheat protector. Please remove the Motor overheat reasons first and then relieve ALARM after Motor cooling.</p> <p>Please confirm the AC cable \ Motor connector is in a bad connection \ disconnected or not.</p>
	ALARM lamp not lighting up	<p>Please confirm the capacitor is consistent with the Motor splicing or not.</p> <p>Please confirm the electromagnetic brake connection is correct or not.</p> <p>Please confirm the contacts ④ ⑤ ⑧ input status and wiring condition.</p> <p>Please confirm that whether the SINK/SOURCE switch is consistent with the wiring or not.</p>
Motor running direction is opposite to the specified direction		Please confirm the contacts ⑤ ⑧ input status and wiring condition; also make sure that whether the gearhead has reverse characteristics or not.
Motor does not brake Electromagnetic brake does not keep holding		Please confirm the contacts ④ brake relieve input is "ON" or not.

※If the operation condition is still abnormal condition through treatment, please contact with the salesman.

※Important

## Operation Precaution

- Before supplying AC power , do not enter CW rotation input 、 CCW rotation input 、 brake release input. These input conditions which are turned "ON" will make ALARM light up and the ALARM output will be "OFF".
- When switching the rotation direccition-CW rotation input and CCW rotation input are "ON" at the same time, please regard the CW rotation input as a priority.
- It can conduct instantaneous CW/CCW rotation with 6R, 8R, 9R series Reversible Motor.
- When conducting CW/CCW rotation with 6I, 8I, 9I series Induction motor, make sure that the Motor has stopped completely then switch the rotation direction.
- The BRAKE STOP function is electronic brake. After braking for 0.5 seconds, the Motor will have no holding torque. If you need BRAKE STOP function, please use with TROY's Electromagnetic Brake Motor series to keep the Motor stop for a long time.
- If you use BRAKE STOP function, please keep the using frequency at above 4 seconds (run for 2 seconds and stop for 2 seconds) Observe the repetition cycle given in the table below for the operation and braking of the Motor, and the Motor may generate heat depending on the conditions in which it is driven. Besure to keep the temperature of Motor case does not exceed 90°C

Motor output power	Operation/braking repetition cycle
6-40W	Min. 2 seconds (run for 1 second and stop for 1 second)
60W 、 90W	Min. 4 seconds (run for 2 seconds and stop for 2 seconds)

※ Please inquiry with local officer or distributor to choose product

**TROY** 泰映科技股份有限公司

TROY ENTERPRISE CO., LTD **Motor manufacturer**

www.troy.com.tw

Made in Taiwan



• ISO 9001 : 2008  
• ISO 14001 : 2004



※Responsibility of environment protection

We place important on spreading environment protection. Each package can be recycled. Please using litter dealing process and recycling to replace the old product.

--- By your attending, we protect the earth together. ---

※ We won't inform individually if we promote the product characteristics. Please inquiry with each office. Thank you very much.